

LOAD RATINGS

RATING	Lbs
RADIAL BASIC DYNAMIC	2,225
MAXIMUM STATIC CAPACITY	6,120

NOTES:

1. BEARING IS PACKED WITH LITHIUM BASED #2 WEIGHT GREASE
2. ALL EXPOSED SURFACES HAVE BLACK OXIDE

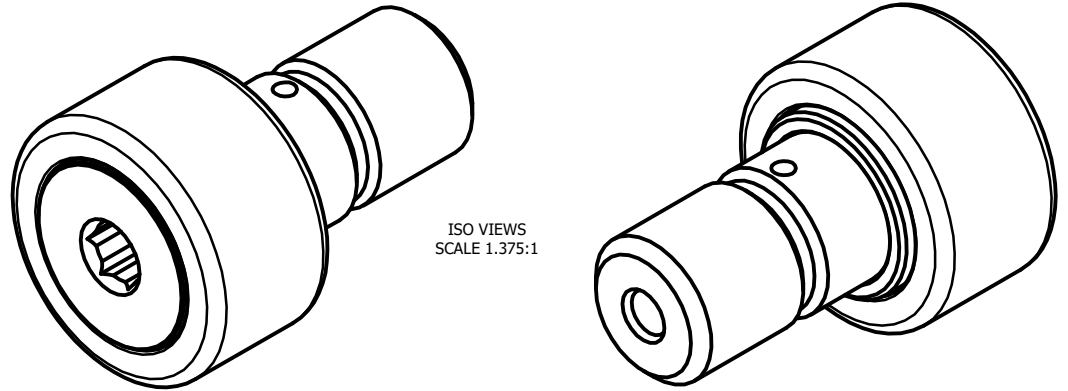

ISO VIEWS
SCALE 1.375:1

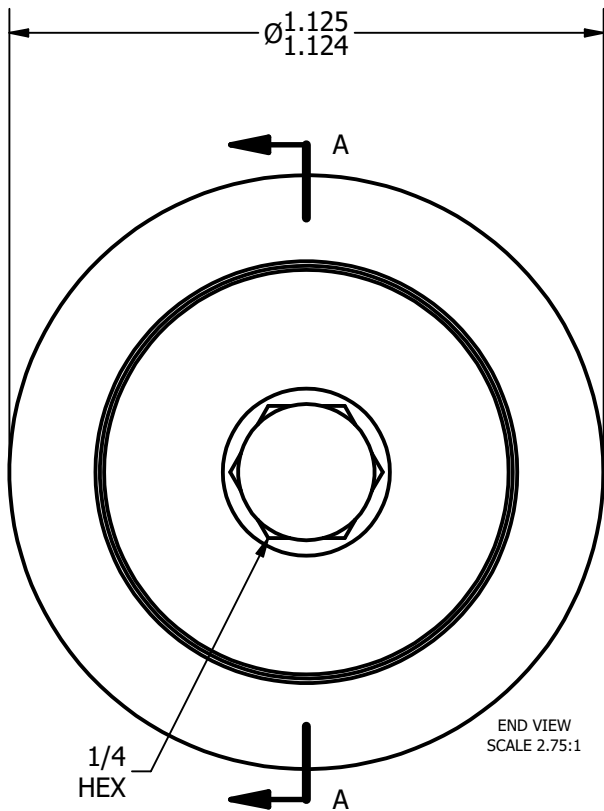

END VIEW
SCALE 2.75:1

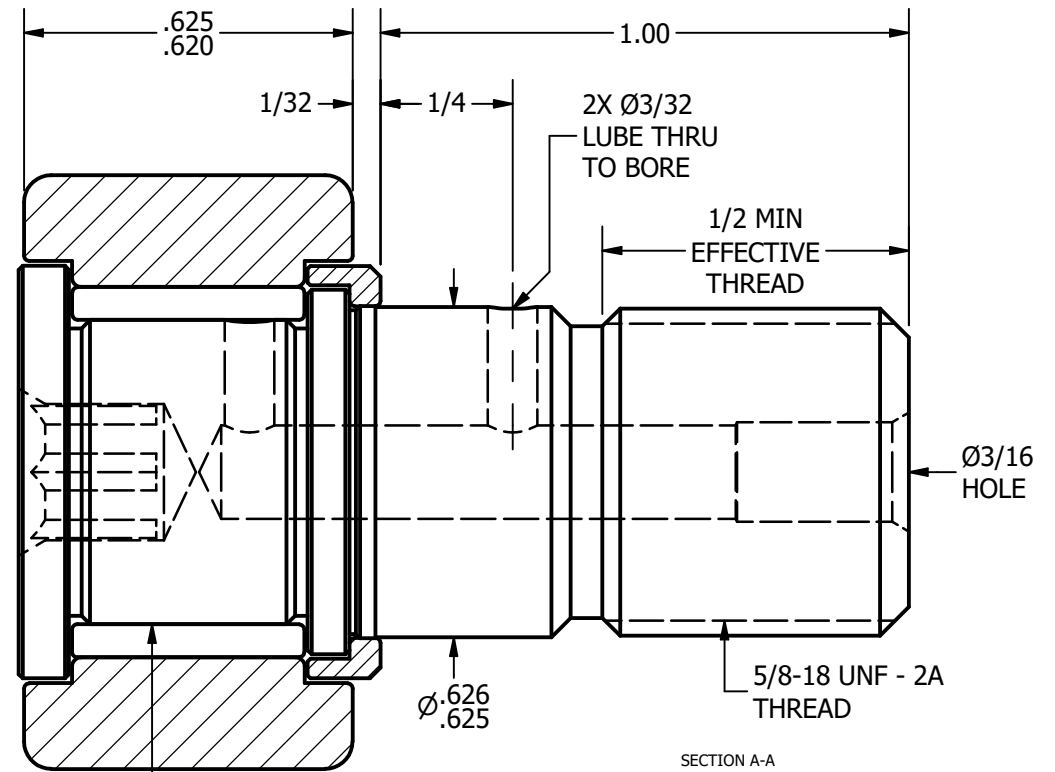

SECTION A-A
SCALE 2.75:1

MATERIAL NOTES:

OUTER RACE - BEARING STEEL, HEAT TREATED
 STUD - BEARING STEEL, ZONE HARDENED
 NEEDLE ROLLER - BEARING STEEL, HEAT TREATED
 WASHER - COLD ROLLED STEEL, HEAT TREATED

CUSTOMER PART#

.XX = ± .01
 .XXX = ± .005
 .XXXX = ± .0005
 ANGLES = ± 1'
 INCH [METRIC]
 FRACTION = ± 1/32

CHANGE NOTE:

CARTER MANUFACTURING IS NOT RESPONSIBLE FOR TYPOGRAPHICAL ERRORS

CARTER MANUFACTURING CO., INC.

GRAND HAVEN, MICHIGAN 49417

REVISION

PART NAME: ASSEMBLY

SHEET 1 OF 2

B

AUTHOR. BY

DRAWN BY

CHK'D BY

SALES

MATERIAL

DB

EMD

MD

KR

NOTED

REV. BY

SGW

DATE

5/6/2013

DATE

6/27/2006

DATE

5/6/2013

DATE

5/6/2013

DRAWING NO.

CNBH-36-B