

LOAD RATINGS		
RATING	Lbs	Newtons
RADIAL BASIC DYNAMIC	1,660	7,384
MAXIMUM STATIC CAPACITY	4,130	18,371

MS NO. _____ NSN NO. _____ DRAWING NO. CNBH-28-B

RECOMMENDED MOUNTING HOLE Ø		
Limit	Inch	mm
MIN	.4375	11.1125
MAX	.4380	11.1252

- NOTES:
1. BEARING IS PACKED WITH NLGI GRADE 2, LITHIUM BASED GREASE (UNLESS OTHERWISE SPECIFIED)
 2. ALL EXPOSED SURFACES HAVE BLACK OXIDE
 3. CUSTOM LASER ETCHING IS AVAILABLE UPON REQUEST
 4. LIMITING SPEED:
A. GREASE = 5,400 RPM

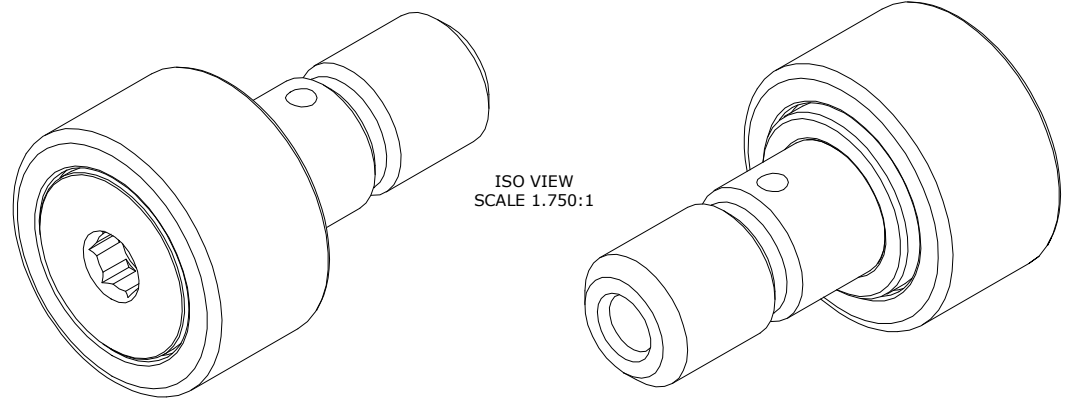

MAXIMUM CLAMPING TORQUE**		
Thread Type	Inch Lbs	Nm
LUBRICATED	125	14.1

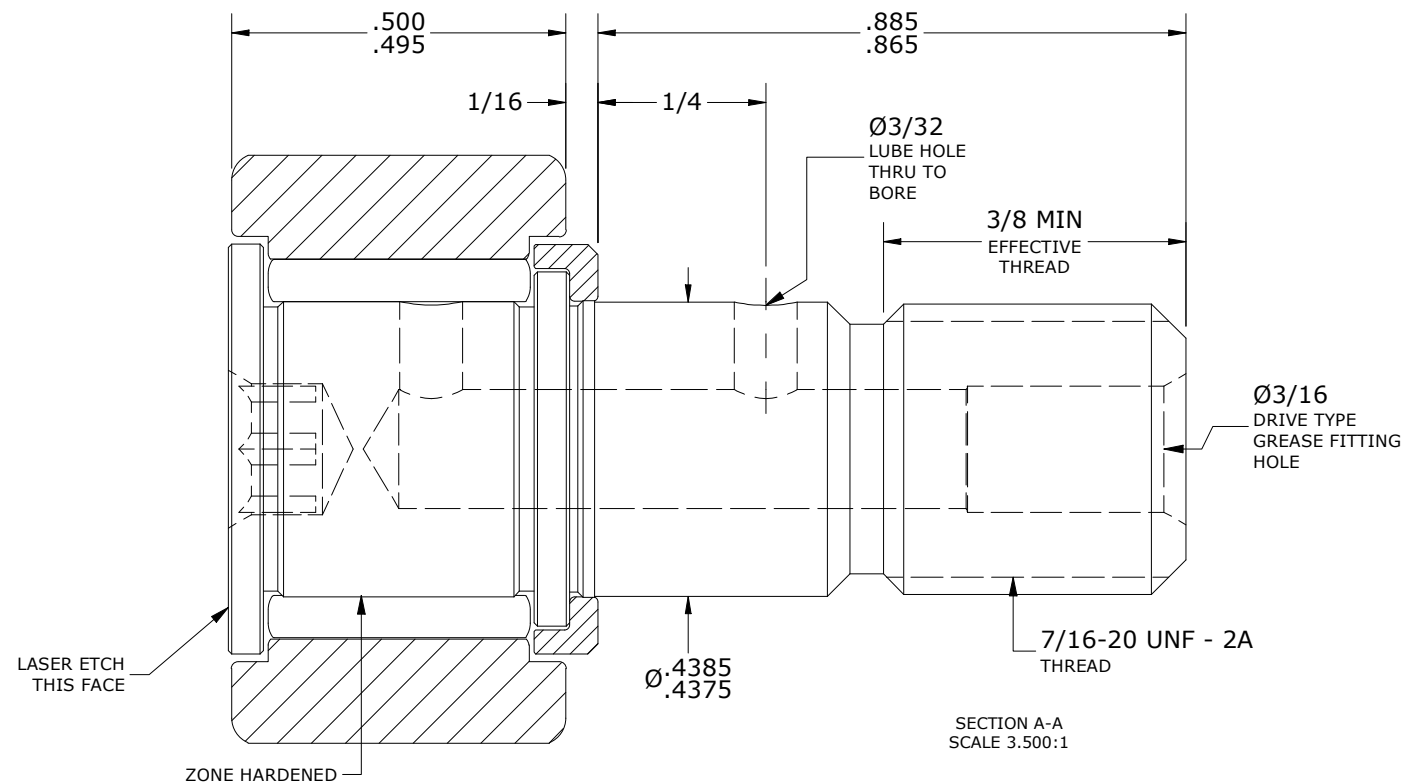
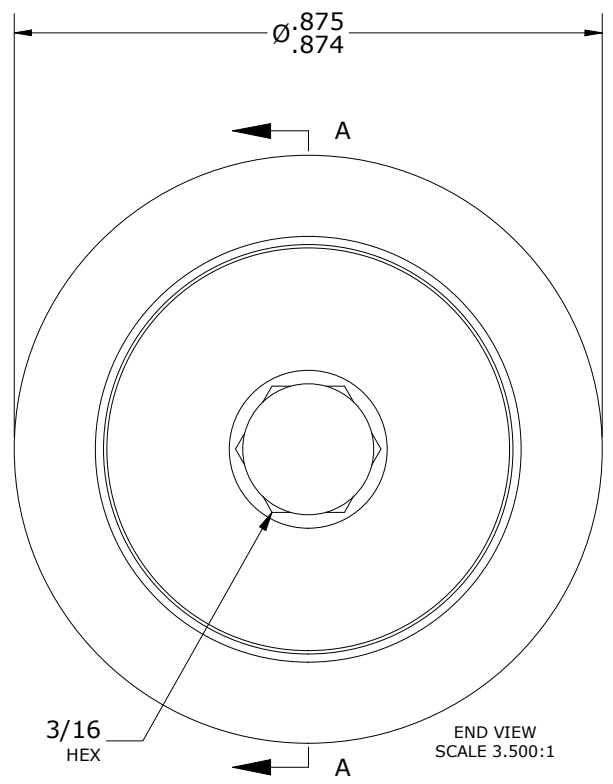

**TORQUE SPECIFICATION IS BASED ON LUBRICATED THREADS, IF USING DRY THREADS DOUBLE TORQUE VALUE

MATERIAL NOTES:

OUTER RING - BEARING STEEL, HEAT TREATED
 STUD - BEARING STEEL, ZONE HARDENED
 NEEDLE ROLLER(S) - BEARING STEEL, HEAT TREATED
 WASHER - BEARING STEEL, HEAT TREATED

CUSTOMER PART#	XX = ± .01 XXX = ± .005 XXXX = ± .0005 ANGLES = ± 1' INCH [METRIC] FRACTION = ± 1/32
ENGINEERING CHANGE ORDER NOTE	

CARTER MANUFACTURING IS NOT RESPONSIBLE FOR TYPOGRAPHICAL ERRORS				CARTER MANUFACTURING CO., INC. GRAND HAVEN, MICHIGAN 49417			
REVISION		PART NAME: ASSEMBLY		PRODUCT TYPE: CNBH			
C	AUTHOR BY HG	DRAWN BY GJP	CHK'D BY MD	SALES KR	MATERIAL NOTED		
REVISION BY SGW	DATE 6/23/2020	DATE 12/6/1999	DATE 6/22/2020	DATE 5/5/2017	SHEET 1 OF 2		