

LOAD RATINGS		
RATING	Lbs	Newtons
RADIAL BASIC DYNAMIC	11,720	52,133
MAXIMUM STATIC CAPACITY	16,450	73,173

RECOMMENDED MOUNTING HOLE		
LIMIT	Inch	mm
MIN.	1.377	34.9759
MAX.	1.379	35.0267

MAXIMUM CLAMPING TORQUE **		
Thread Type	Inch lbf	Nm
LUBRICATED	1,125	127

NOTES:

1. BEARING IS PACKED WITH NLGI GRADE 2, LITHIUM BASED GREASE UNLESS OTHERWISE SPECIFIED
2. ALL EXPOSED SURFACES HAVE BLACK OXIDE
3. CUSTOM LASER ETCHING IS AVAILABLE UPON REQUEST
4. LIMITING SPEED:
 - A. GREASE = 1,100 RPM

MS NO.

NSN NO.

DRAWING NO.

CNBE-80-SB

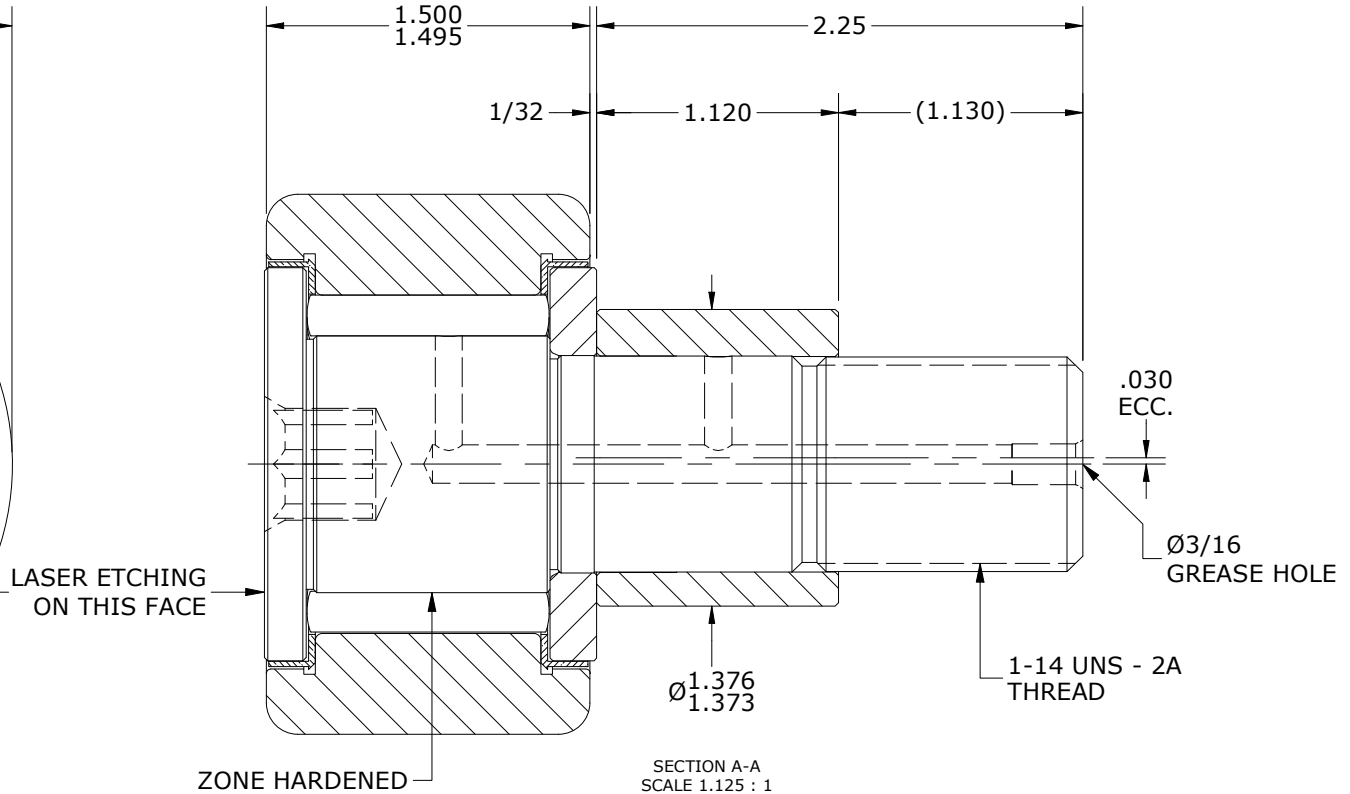
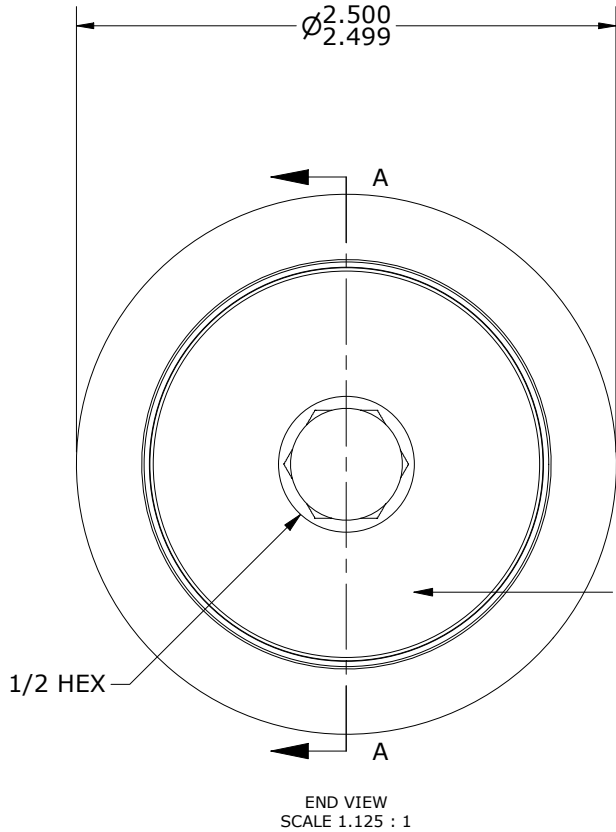
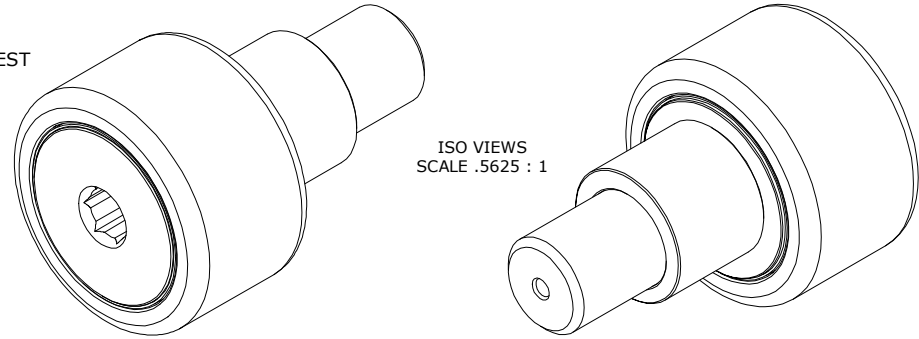

** TORQUE SPECIFICATION IS BASED ON LUBRICATED THREADS, IF USING CLEAN DRY THREADS DOUBLE TORQUE VALUE

MATERIAL NOTES:

OUTER RING - BEARING STEEL, HEAT TREATED
 STUD - BEARING STEEL, ZONE HARDENED
 NEEDLE ROLLERS - BEARING STEEL, HEAT TREATED
 WASHER - STEEL, HEAT TREATED
 SEALS - SYNTHETIC
 ECCENTRIC SLEEVE - STEEL

CUSTOMER PART#

XX = ± .01
 XXX = ± .005
 XXXX = ± .0005
 ANGLES = ± 1'
 INCH [METRIC]
 FRACTION = ± 1/32

CARTER MANUFACTURING IS NOT RESPONSIBLE FOR TYPOGRAPHICAL ERRORS

CARTER MANUFACTURING CO., INC.

GRAND HAVEN, MICHIGAN 49417

ENGINEERING CHANGE ORDER NOTE

REVISION

PART NAME: ASSEMBLY

PRODUCT TYPE: CNBE

C

AUTHOR BY

DRAWN BY

CHK'D BY

SALES

MATERIAL

HG

GJP

SGW

KR

NOTED

REVISION BY

DATE

DATE

DATE

DATE

SHEET

MD

7/14/2021

8/14/2000

7/14/2021

11/5/2018

1 OF 2