

LOAD RATINGS		
RATING	lbf	Newtons
RADIAL BASIC DYNAMIC	8,090	35,986
MAXIMUM STATIC CAPACITY	10,570	47,018

MS NO. _____ NSN NO. _____ DRAWING NO. CNBE-64-S

RECOMMENDED MOUNTING HOLE Ø		
Limit	Inch	mm
MIN	1.189	30.2006
MAX	1.191	30.2514

- NOTES:
- BEARING IS PACKED WITH NLGI GRADE 2, LITHIUM BASED GREASE (UNLESS OTHERWISE SPECIFIED)
 - ALL EXPOSED SURFACES HAVE BLACK OXIDE
 - LIMITING SPEED:
 - A. GREASE = 1,400 RPM

MAXIMUM CLAMPING TORQUE		
Thread Type	Inch Lbs	Nm
DRY	1500	169.5
LUBRICATED	750	84.7

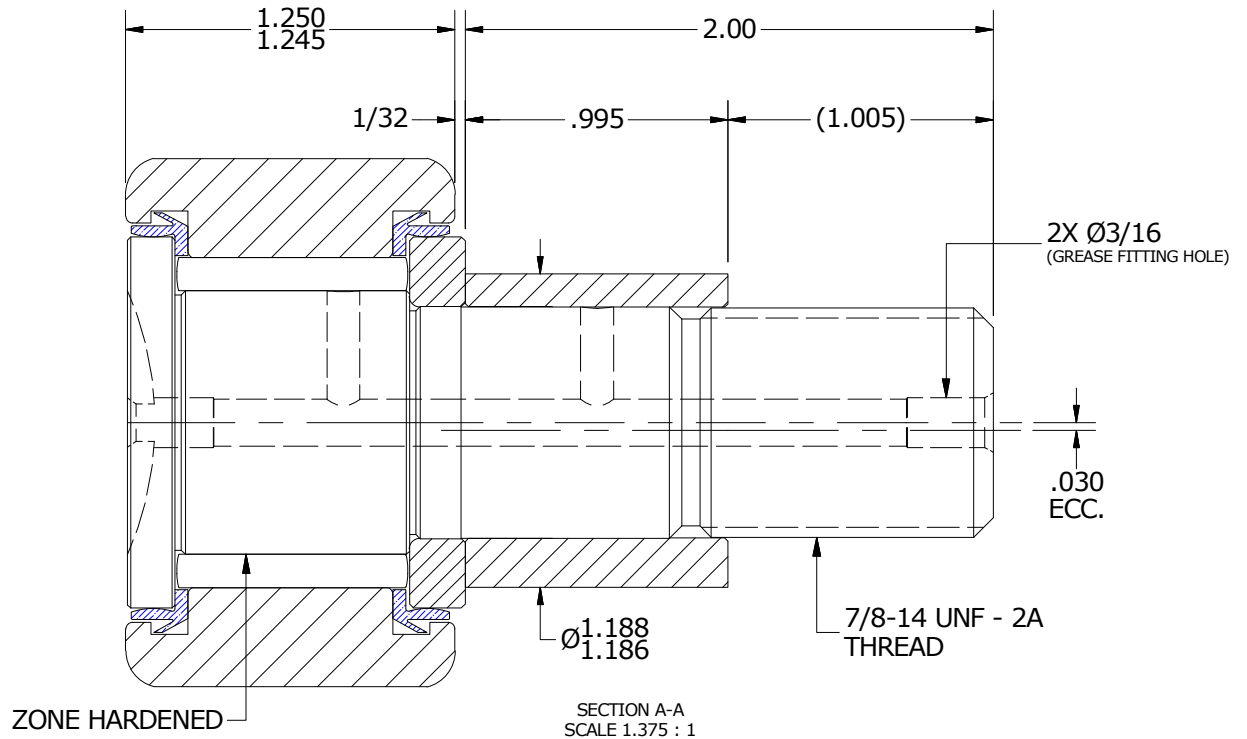
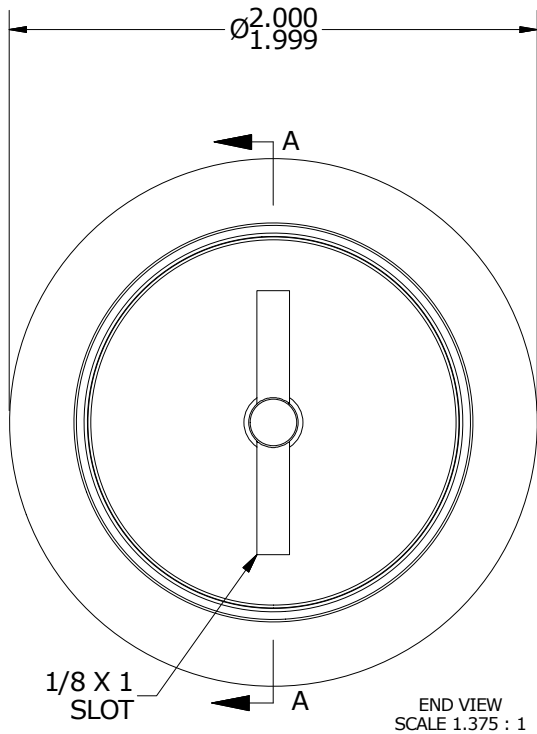
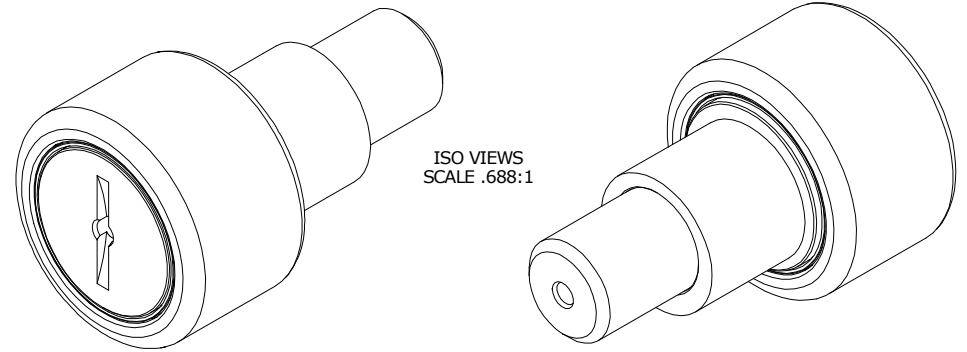

MATERIAL NOTES:

- OUTER RING - BEARING STEEL, HEAT TREATED
- STUD - BEARING STEEL, ZONE HARDENED
- NEEDLE ROLLER(S) - BEARING STEEL, HEAT TREATED
- WASHER - BEARING STEEL, HEAT TREATED
- ECCENTRIC SLEEVE - COLD ROLLED STEEL
- SEAL(S) - SYNTHETIC

CUSTOMER PART#

XX = ± .01
XXX = ± .005
XXXX = ± .0005
ANGLES = ± 1'
INCH [METRIC]
FRACTION = ± 1/32

CARTER MANUFACTURING IS NOT RESPONSIBLE FOR TYPOGRAPHICAL ERRORS

CARTER MANUFACTURING CO., INC.

GRAND HAVEN, MICHIGAN 49417

ENGINEERING CHANGE ORDER NOTE

REVISION

PART NAME: ASSEMBLY

PRODUCT TYPE: CNB

B

AUTHOR BY

DRAWN BY

CHK'D BY

SALES

MATERIAL

HG

JAF

MD

KR

NOTED

REVISION BY

DATE

DATE

DATE

DATE

SHEET

SGW

7/26/2018

7/12/2006

7/25/2018

7/25/2018

1 OF 2