

LOAD RATINGS	
RATING	Lbs
RADIAL BASIC DYNAMIC	4,840
MAXIMUM STATIC CAPACITY	5,640

NOTES:
 1. BEARING IS PACKED WITH LITHIUM BASED #2 WEIGHT GREASE
 2. ALL EXPOSED SURFACES HAVE BLACK OXIDE

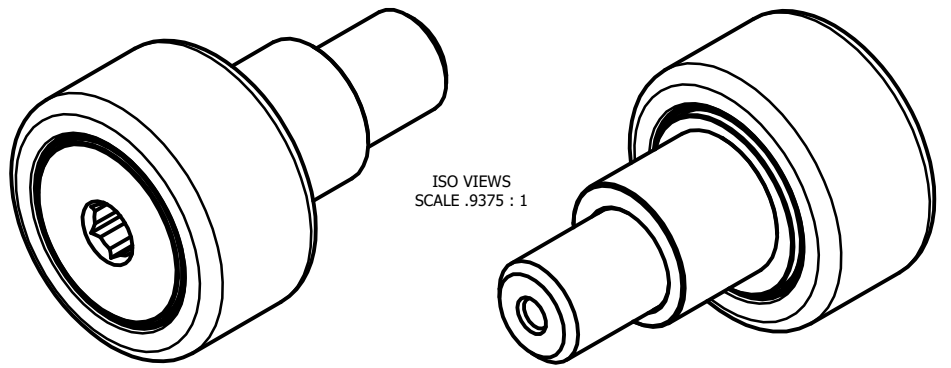

ISO VIEWS
 SCALE .9375 : 1

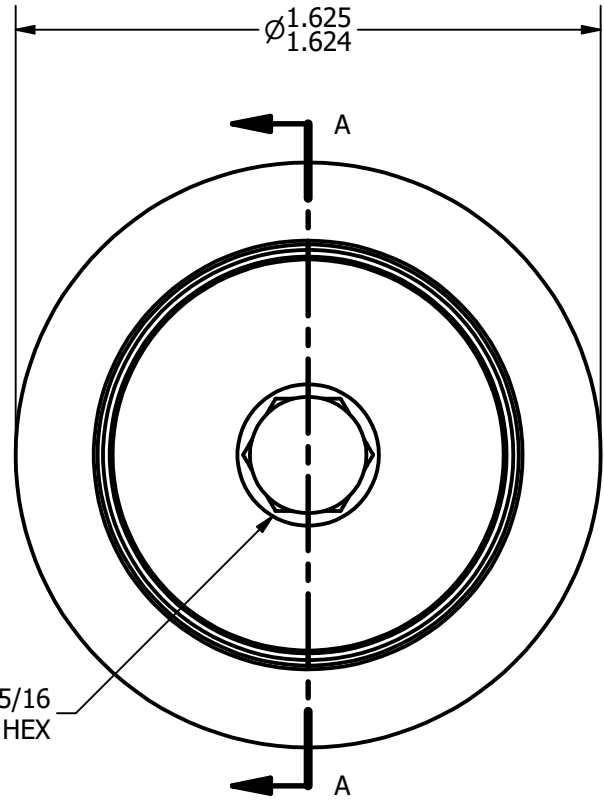

BASE VIEW
 SCALE 1.875 : 1

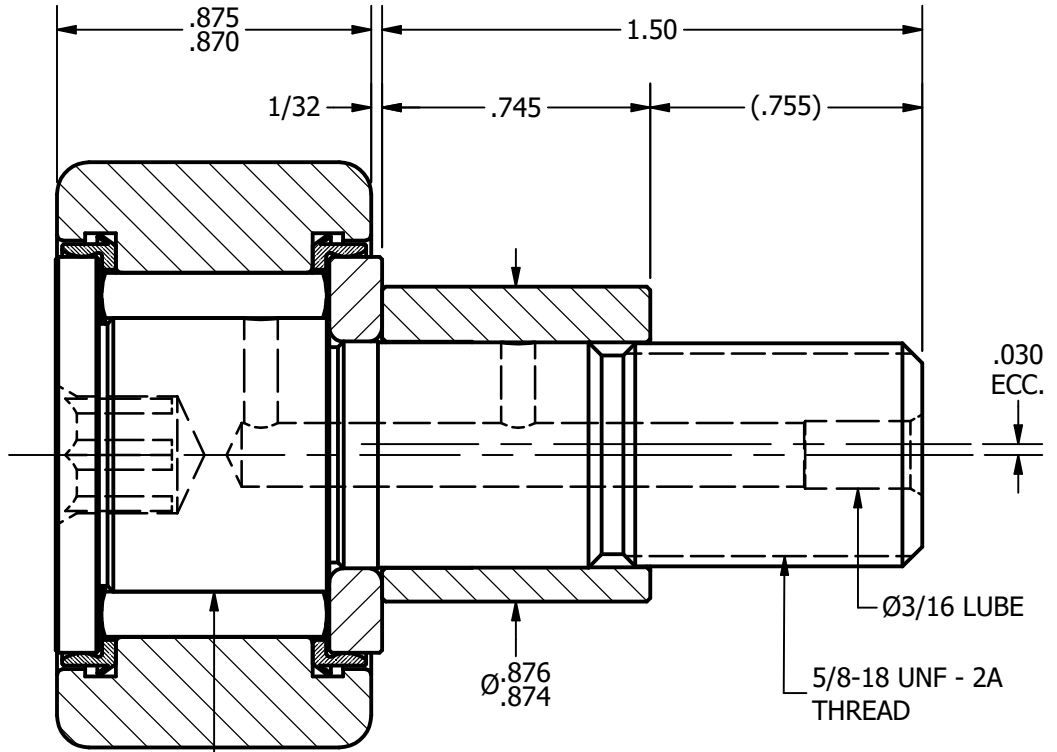

SECTION A-A
 SCALE 1.875 : 1

MATERIAL NOTES:
 OUTER RACE - BEARING STEEL, HEAT TREATED
 STUD - BEARING STEEL, ZONE HARDENED
 NEEDLE ROLLERS - BEARING STEEL, HEAT TREATED
 WASHER - COLD ROLLED STEEL, HEAT TREATED
 ECCENTRIC SLEEVE - COLD ROLLED STEEL
 SEALS - SYNTHETIC

CUSTOMER PART#	.XX = ± .01 .XXX = ± .005 .XXXX = ± .0005 ANGLES = ± 1' INCH [METRIC] FRACTION = ± 1/32
CHANGE NOTE:	

CARTER MANUFACTURING IS NOT RESPONSIBLE FOR TYPOGRAPHICAL ERRORS	
REVISION	
B	AUTHOR. BY DB
REV. BY	DATE
MD	4/4/2013

CARTER MANUFACTURING CO., INC.					
GRAND HAVEN, MICHIGAN 49417					
PART NAME: Assembly			SHEET 1 OF 2		
	AUTHOR. BY	DRAWN BY	CHK'D BY	SALES	MATERIAL
	DB	JAF	SGW	KPR	NOTED
	DATE	DATE	DATE	DATE	DRAWING NO.
	4/4/2013	7/14/2006	4/4/2013	7/13/2006	CNBE-52-SB