

LOAD RATINGS		
RATING	lbf	Newtons
RADIAL BASIC DYNAMIC	3,930	17,481
MAXIMUM STATIC CAPACITY	4,250	18,904

MS NO.	NSN NO.	DRAWING NO.
--------	---------	-------------

RECOMMENDED MOUNTING HOLE Ø		
Limit	Inch	mm
MIN	.689	17.501
MAX	.691	17.551

- NOTES:
1. BEARING IS PACKED WITH NLGI GRADE 2, LITHIUM BASED GREASE (UNLESS OTHERWISE SPECIFIED)
 2. ALL EXPOSED STEEL SURFACES HAVE BLACK OXIDE
 3. LIMITING SPEED:
A. GREASE = 3,100 RPM

MAXIMUM CLAMPING TORQUE		
Thread Type	Inch Lbs	Nm
DRY	350	40
LUBRICATED	175	20

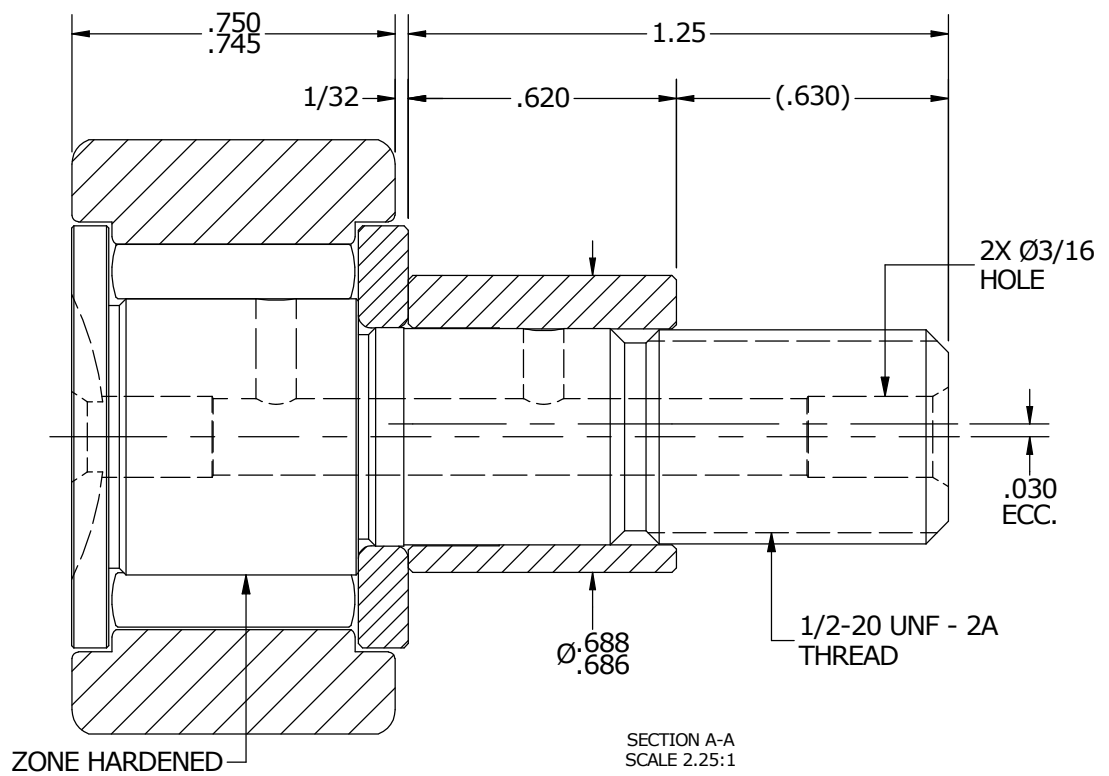
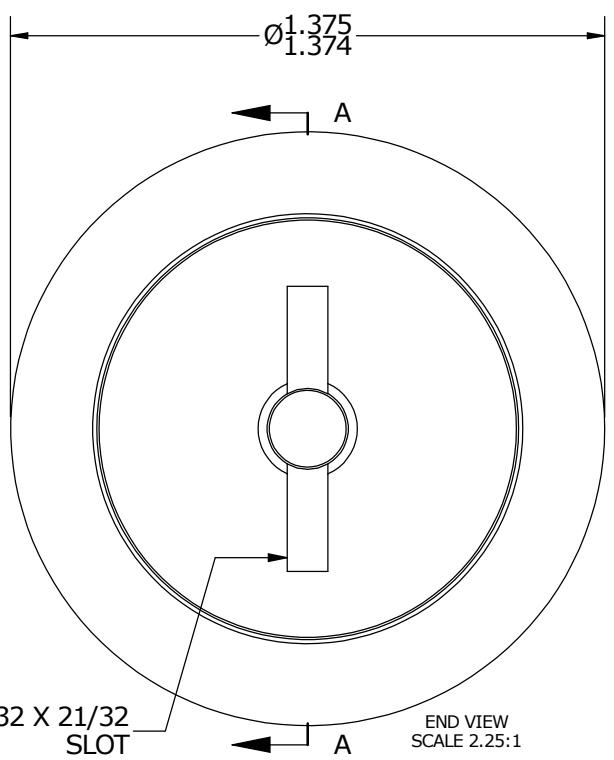
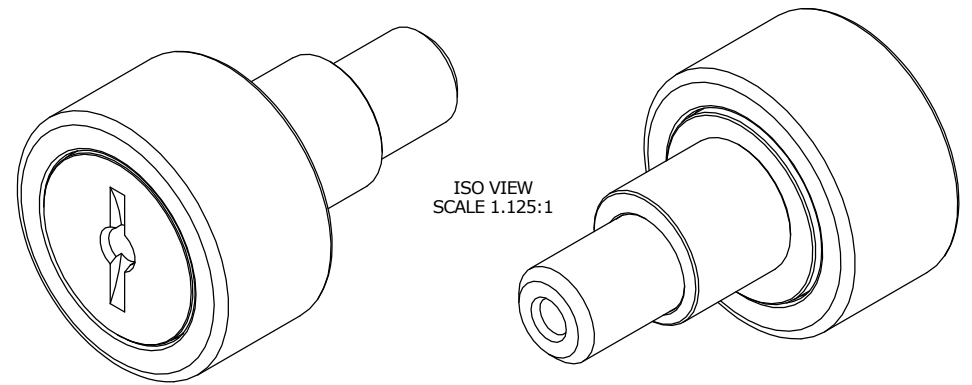

MATERIAL NOTES:

OUTER RING - BEARING STEEL, HEAT TREATED
 STUD - BEARING STEEL, ZONE HARDENED
 NEEDLE ROLLER - BEARING STEEL, HEAT TREATED
 WASHER - BEARING STEEL, HEAT TREATED*
 ECCENTRIC SLEEVE - COLD ROLLED STEEL

*(MAY BE CONSTRUCTED FROM COLD ROLLED STEEL DEPENDING ON MATERIAL AVAILABILITY)

CUSTOMER PART#	XX = ± .01 XXX = ± .005 XXXX = ± .0005 ANGLES = ± 1' INCH [METRIC] FRACTION = ± 1/32
ENGINEERING CHANGE ORDER NOTE	

CARTER MANUFACTURING IS NOT RESPONSIBLE FOR TYPOGRAPHICAL ERRORS		CARTER MANUFACTURING CO., INC. GRAND HAVEN, MICHIGAN 49417			
REVISION		PART NAME: ASSEMBLY			
B	AUTHOR BY HG	DRAWN BY JAF	CHK'D BY MD	SALES KR	MATERIAL NOTED
REVISION BY SGW	DATE 6/30/2016	DATE 6/30/2006	DATE 6/14/2016	DATE 7/15/2016	SHEET 1 OF 2