

LOAD RATINGS		
RATING	lbf	Newtons
RADIAL BASIC DYNAMIC	2,225	9,897
MAXIMUM STATIC CAPACITY	3,060	13,611

NOTES:

- BEARING IS PACKED WITH NLGI GRADE 2, LITHIUM BASED GREASE (UNLESS OTHERWISE SPECIFIED)
- ALL EXPOSED STEEL SURFACES HAVE BLACK OXIDE
- LIMITING SPEED:
 - A. GREASE = 4,800 RPM
- CUSTOM LASER ETCHING UPON REQUEST

RECOMMENDED MOUNTING HOLE Ø		
Limit	Inch	mm
MIN	.627	15.926
MAX	.629	15.977

MAXIMUM CLAMPING TORQUE		
Thread Type	Inch Lbs	Nm
DRY	250	28
LUBRICATED	125	14

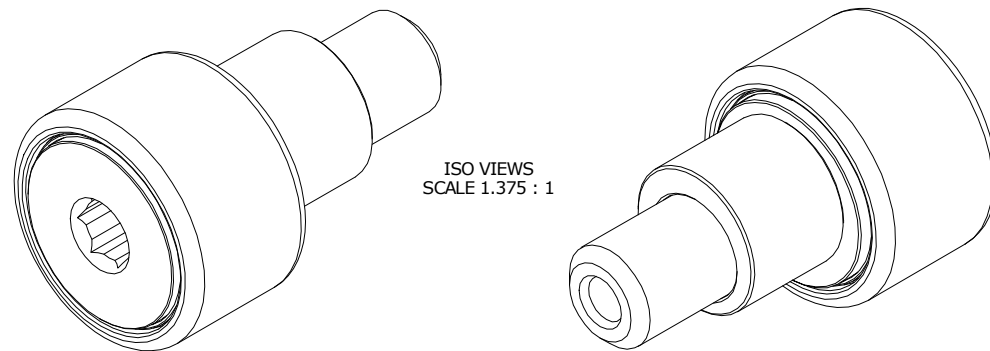

ISO VIEWS
SCALE 1.375 : 1

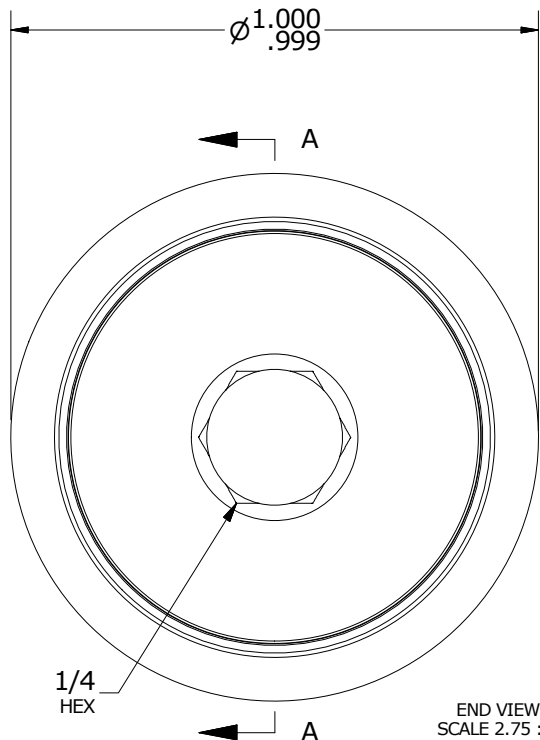

END VIEW
SCALE 2.75 : 1

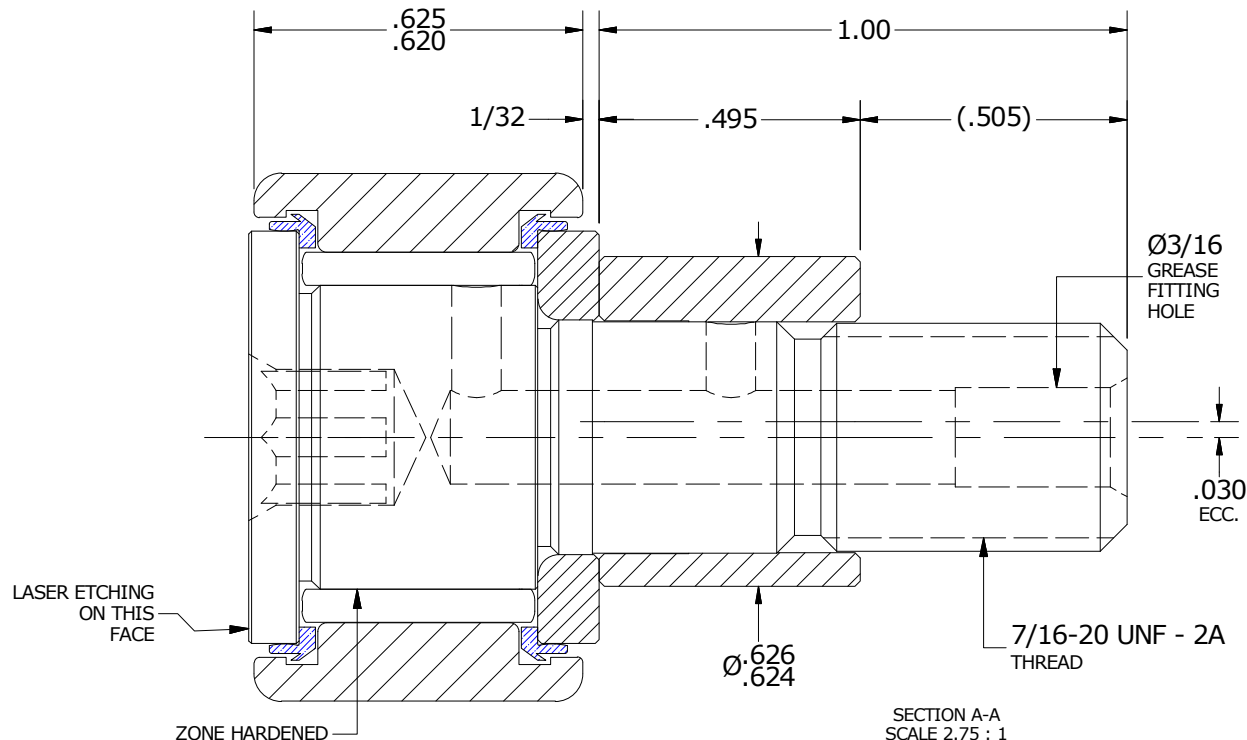

SECTION A-A
SCALE 2.75 : 1

MATERIAL NOTES:

- OUTER RING - BEARING STEEL, HEAT TREATED
- STUD - BEARING STEEL, ZONE HARDENED
- NEEDLE ROLLER(S) - BEARING STEEL, HEAT TREATED
- WASHER - BEARING STEEL, HEAT TREATED
- ECCENTRIC SLEEVE - STEEL
- SEAL(S) - SYNTHETIC

CUSTOMER PART#

XX = ± .01
XXX = ± .005
XXXX = ± .0005
ANGLES = ± 1'
INCH [METRIC]
FRACTION = ± 1/32

CARTER MANUFACTURING IS NOT RESPONSIBLE FOR TYPOGRAPHICAL ERRORS

CARTER MANUFACTURING CO., INC.

GRAND HAVEN, MICHIGAN 49417

ENGINEERING CHANGE ORDER NOTE

REVISION

PART NAME: ASSEMBLY

PRODUCT TYPE: CNB

C

AUTHOR BY
DB

DRAWN BY
JAF

CHK'D BY
MD

SALES
KR

MATERIAL
NOTED

REVISION BY
SGW

DATE
4/24/2013

DATE
6/26/2006

DATE
4/24/2013

DATE
4/23/2013

SHEET
1 OF 2