

LOAD RATINGS		
RATING	Lbs	Newtons
RADIAL BASIC DYNAMIC	1,660	7,384
MAXIMUM STATIC CAPACITY	2,065	9,185

MS NO. _____ NSN NO. _____ DRAWING NO. CNBE-28-S

RECOMMENDED MOUNTING HOLE Ø		
Limit	Inch	mm
MIN	.502	12.7508
MAX	.504	12.8016

- NOTES:
1. BEARING IS PACKED WITH NLGI GRADE 2, LITHIUM BASED GREASE (UNLESS OTHERWISE SPECIFIED)
 2. ALL EXPOSED SURFACES HAVE BLACK OXIDE
 3. CUSTOM LASER ETCHING IS AVAILABLE UPON REQUEST
 4. LIMITING SPEED:
 - A. GREASE = 5,400 RPM

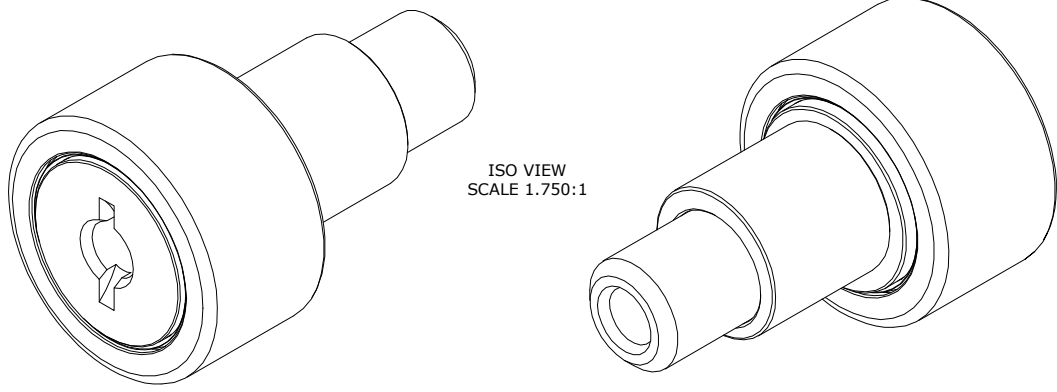

MAXIMUM CLAMPING TORQUE**		
Thread Type	Inch Lbs	Nm
LUBRICATED	47.5	5.5

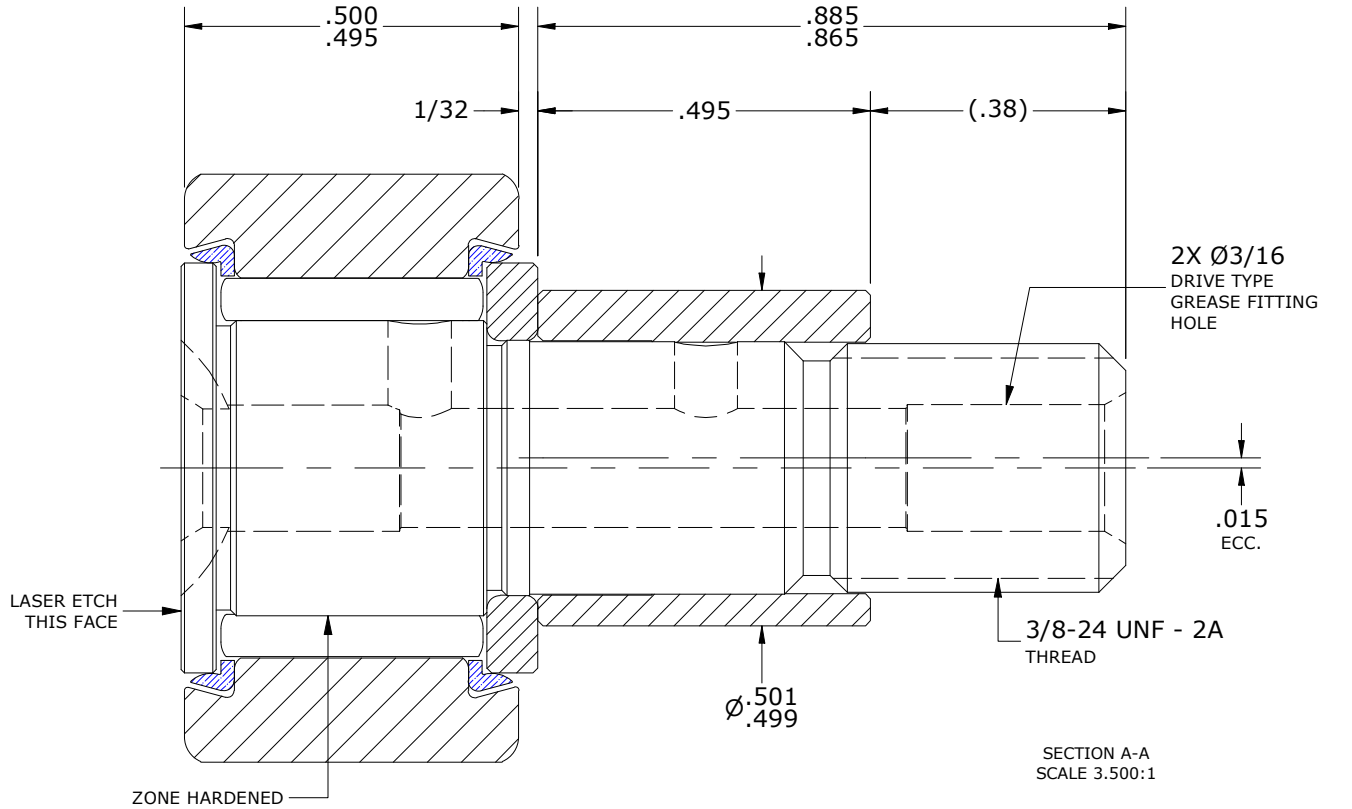
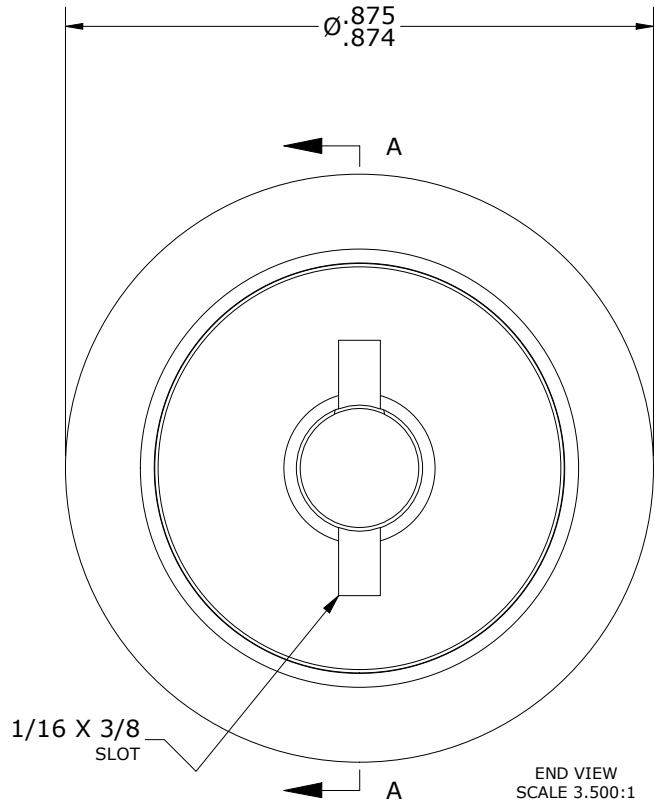

**TORQUE SPECIFICATION IS BASED ON LUBRICATED THREADS, IF USING DRY THREADS DOUBLE TORQUE VALUE

MATERIAL NOTES:

OUTER RING - BEARING STEEL, HEAT TREATED
 STUD - BEARING STEEL, ZONE HARDENED
 NEEDLE ROLLER(S) - BEARING STEEL, HEAT TREATED
 WASHER - BEARING STEEL, HEAT TREATED
 ECCENTRIC SLEEVE - STEEL
 SEAL(S) - SYNTHETIC

CUSTOMER PART# _____
 XX = ± .01
 XXX = ± .005
 XXXX = ± .0005
 ANGLES = ± 1'
 INCH [METRIC]
 FRACTION = ± 1/32

CARTER MANUFACTURING IS NOT RESPONSIBLE FOR TYPOGRAPHICAL ERRORS

CARTER MANUFACTURING CO., INC.
 GRAND HAVEN, MICHIGAN 49417

ENGINEERING CHANGE ORDER NOTE	
C	
REVISION BY	DATE
SGW	6/4/2020

REVISION				PART NAME: ASSEMBLY		PRODUCT TYPE: CNBE	
AUTHOR BY	DRAWN BY	CHK'D BY	SALES	MATERIAL			
HG	JAF	MD	KR	NOTED			
DATE	DATE	DATE	DATE	DATE	SHEET		
6/4/2020	6/23/2006	6/4/2020	5/5/2017		1 OF 2		