

LOAD RATINGS		
RATING	lbf	Newtons
RADIAL BASIC DYNAMIC	11,720	52,133
MAXIMUM STATIC CAPACITY	16,450	73,173

- NOTES:
- BEARING IS PACKED WITH NLGI GRADE 2, LITHIUM BASED GREASE (UNLESS OTHERWISE SPECIFIED)
 - ALL EXPOSED SURFACES HAVE BLACK OXIDE
 - LIMITING SPEED:
A. GREASE = 1,050 RPM

MS NO.	NSN NO.	DRAWING NO.	CNB-88-SB
--------	---------	-------------	-----------

RECOMMENDED MOUNTING HOLE Ø		
Limit	Inch	mm
MIN	1.0000	25.4000
MAX	1.0005	25.4127

MAXIMUM CLAMPING TORQUE		
Thread Type	Inch lbf	Nm
DRY	2,250	254
LUBRICATED	1,125	127

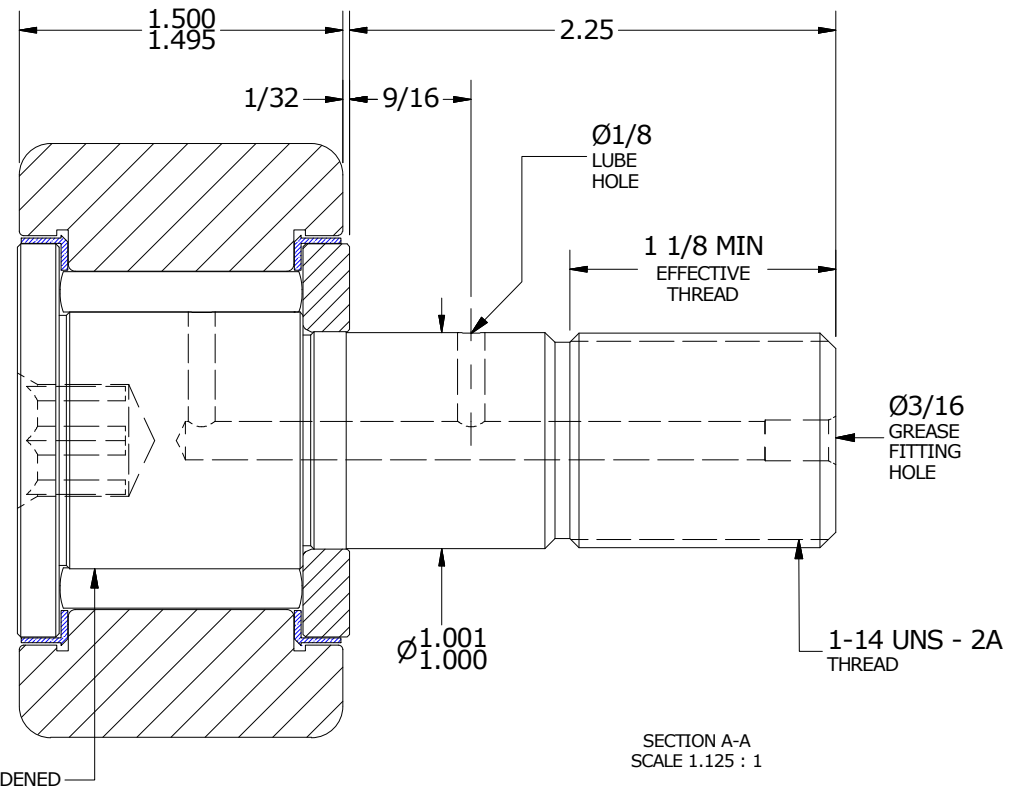
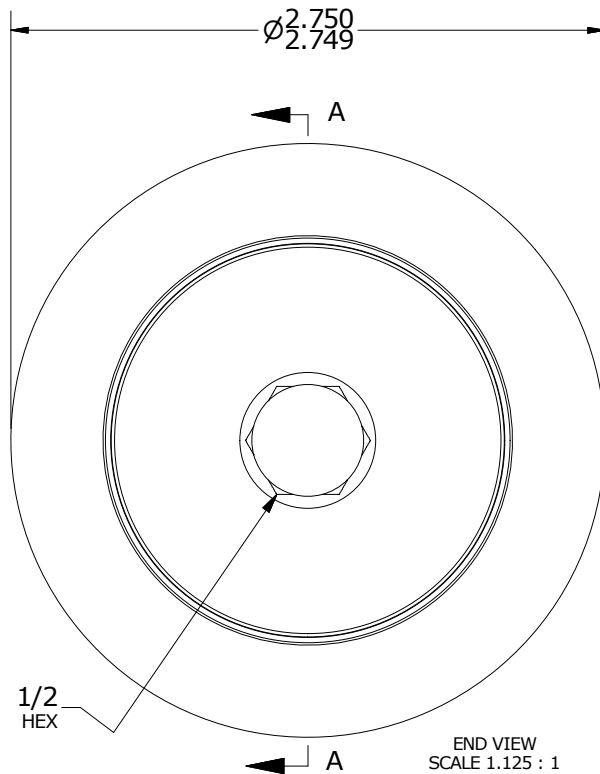
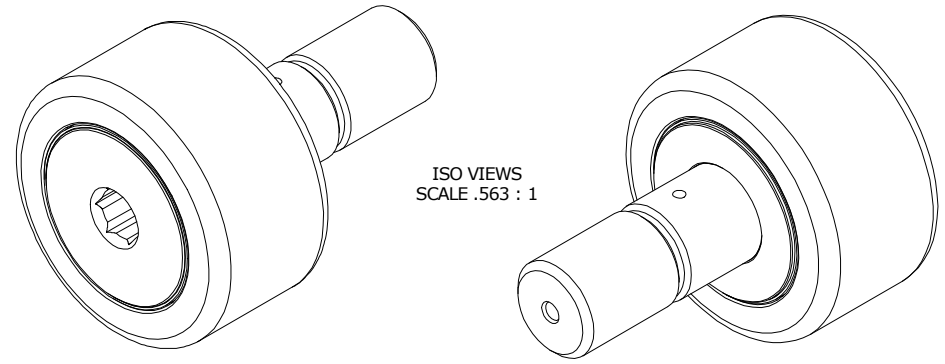

MATERIAL NOTES:

OUTER RING - BEARING STEEL, HEAT TREATED
 STUD - BEARING STEEL, ZONE HARDENED
 NEEDLE ROLLER(S) - BEARING STEEL, HEAT TREATED
 WASHER - BEARING STEEL, HEAT TREATED
 SEAL(S) - SYNTHETIC

CUSTOMER PART#	XX = ± .01 XXX = ± .005 XXXX = ± .0005 ANGLES = ± 1' INCH [METRIC] FRACTION = ± 1/32
ENGINEERING CHANGE ORDER NOTE	

CARTER MANUFACTURING IS NOT RESPONSIBLE FOR TYPOGRAPHICAL ERRORS

CARTER MANUFACTURING CO., INC.
 GRAND HAVEN, MICHIGAN 49417

REVISION		PART NAME: ASSEMBLY			PRODUCT TYPE: CNB	
B	AUTHOR BY HG	DRAWN BY EMD	CHK'D BY MD	SALES KR	MATERIAL NOTED	
REVISION BY SGW	DATE 8/29/2018	DATE 7/11/2006	DATE 8/29/2018	DATE 8/29/2018	SHEET 1 OF 2	