

LOAD RATINGS		
RATING	lbf	Newtons
RADIAL BASIC DYNAMIC	3,930	17,481
MAXIMUM STATIC CAPACITY	4,250	18,904

- NOTES:
1. BEARING IS PACKED WITH NLGI GRADE 2, LITHIUM BASED GREASE (UNLESS OTHERWISE SPECIFIED)
 2. ALL EXPOSED STEEL SURFACES HAVE BLACK OXIDE
 3. CUSTOM LASER ETCHING UPON REQUEST
 4. LIMITING SPEED:
 - A. GREASE = 3,100 RPM

RECOMMENDED MOUNTING HOLE Ø		
Limit	Inch	mm
MIN	.5000	12.7000
MAX	.5003	12.7076

MAXIMUM CLAMPING TORQUE		
Thread Type	Inch Lbs	Nm
DRY	350	40
LUBRICATED	175	20

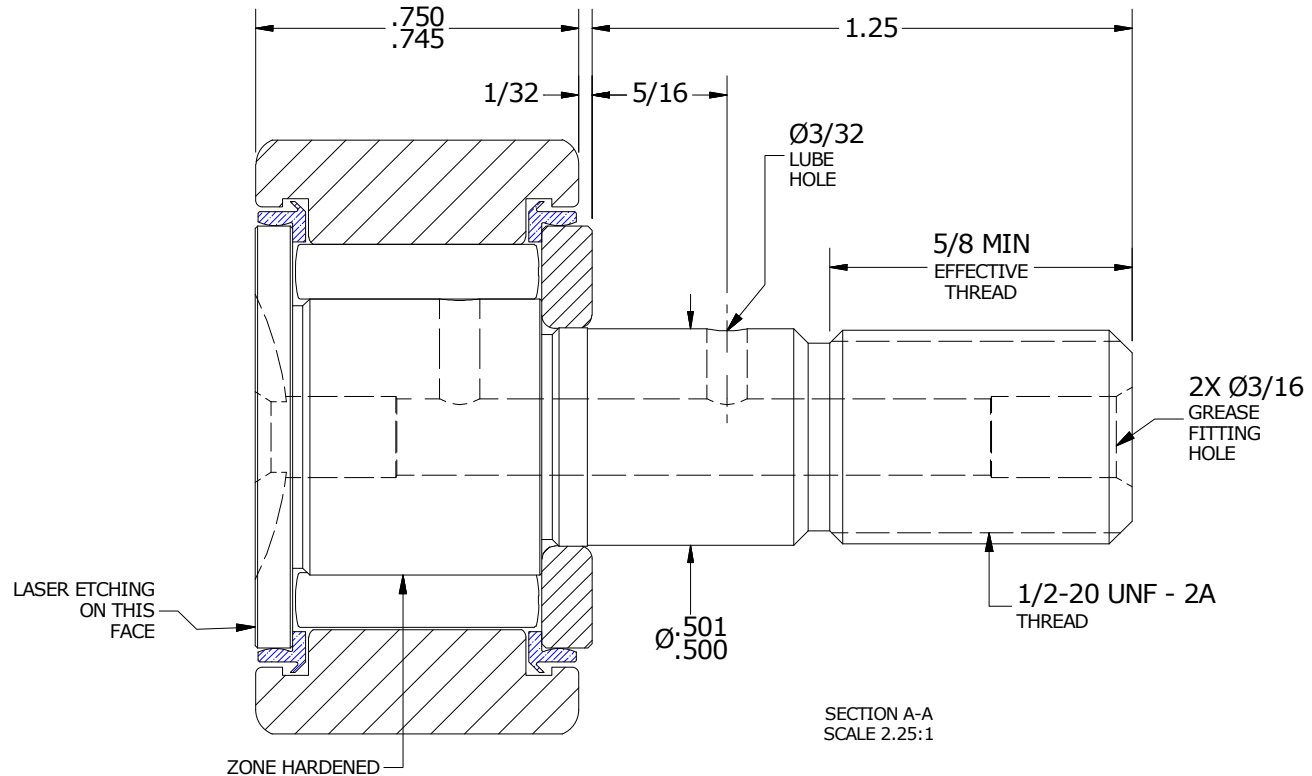
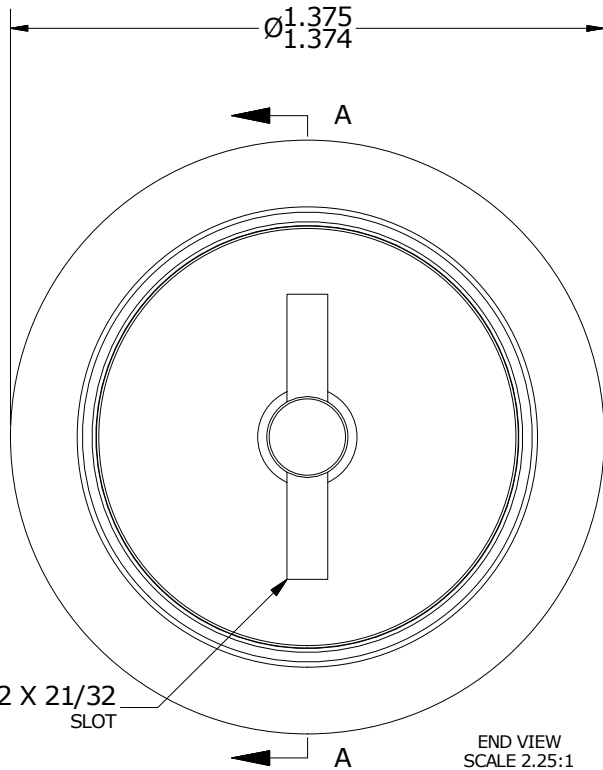
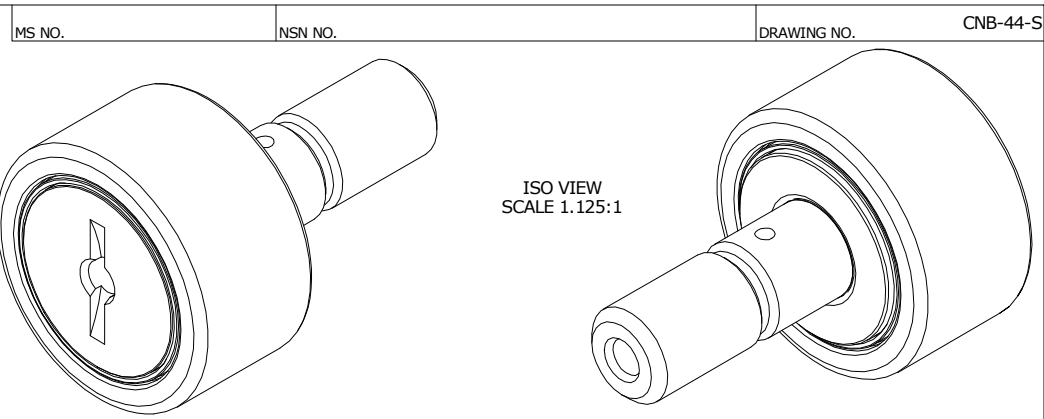

MATERIAL NOTES:

- OUTER RING - BEARING STEEL, HEAT TREATED
- STUD - BEARING STEEL, ZONE HARDENED
- NEEDLE ROLLER(S) - BEARING STEEL, HEAT TREATED
- WASHER - BEARING STEEL, HEAT TREATED
- SEAL(S) - SYNTHETIC

CUSTOMER PART#

XX = ± .01
 XXX = ± .005
 XXXX = ± .0005
 ANGLES = ± 1'
 INCH [METRIC]
 FRACTION = ± 1/32

CARTER MANUFACTURING IS NOT RESPONSIBLE FOR TYPOGRAPHICAL ERRORS

CARTER MANUFACTURING CO., INC.

GRAND HAVEN, MICHIGAN 49417

ENGINEERING CHANGE ORDER NOTE

REVISION

PART NAME: ASSEMBLY

PRODUCT TYPE: CNB

B

AUTHOR BY

DRAWN BY

CHK'D BY

SALES

MATERIAL

HG

GJP

MD

KR

NOTED

REVISION BY

DATE

DATE

DATE

DATE

SHEET

SGW

7/5/2016

11/18/1999

6/7/2016

7/15/2016

1 OF 2