

LOAD RATINGS		
RATING	lbf	Newtons
RADIAL BASIC DYNAMIC	3,930	17,481
MAXIMUM STATIC CAPACITY	4,250	18,904

RECOMMENDED MOUNTING HOLE Ø		
Limit	Inch	mm
MIN	.5000	12.7000
MAX	.5003	12.7076

MAXIMUM CLAMPING TORQUE		
Thread Type	Inch Lbs	Nm
DRY	350	40
LUBRICATED	175	20

- NOTES:
1. BEARING IS PACKED WITH NLGI GRADE 2, LITHIUM BASED GREASE (UNLESS OTHERWISE SPECIFIED)
 2. ALL EXPOSED STEEL SURFACES HAVE BLACK OXIDE
 3. CUSTOM LASER ETCHING UPON REQUEST
 4. LIMITING SPEED:
 - A. GREASE = 3,100 RPM

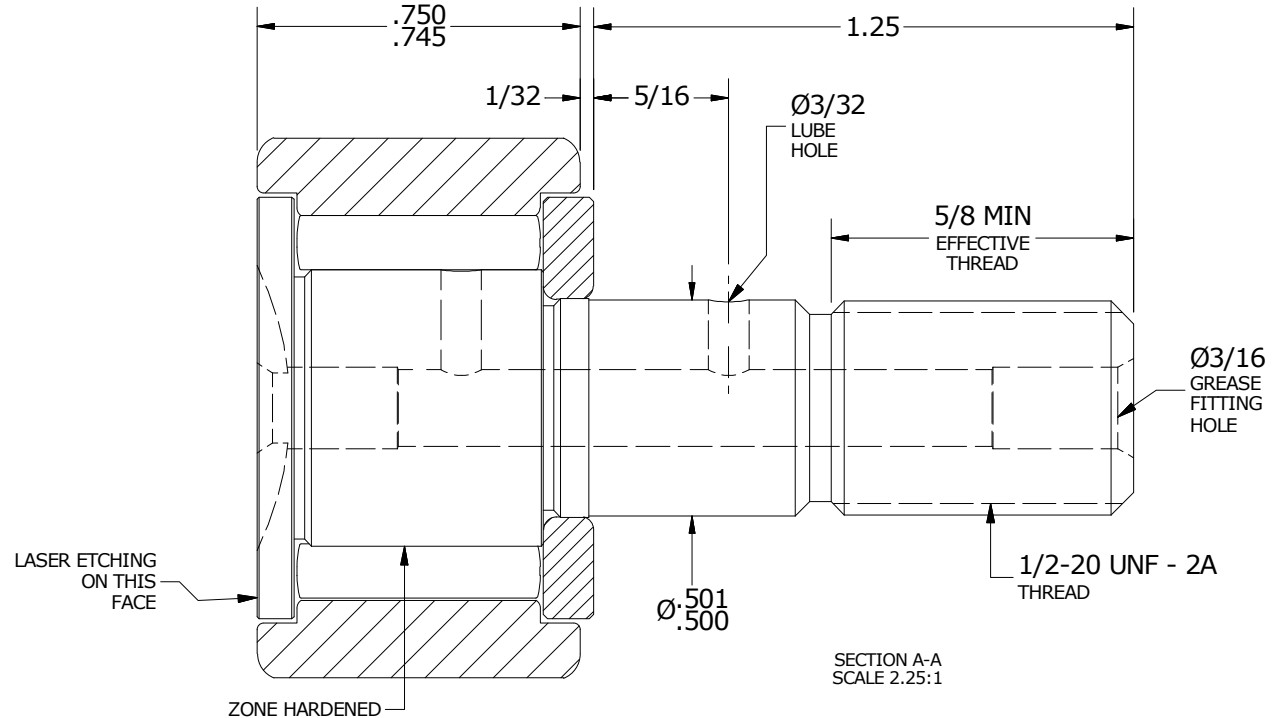
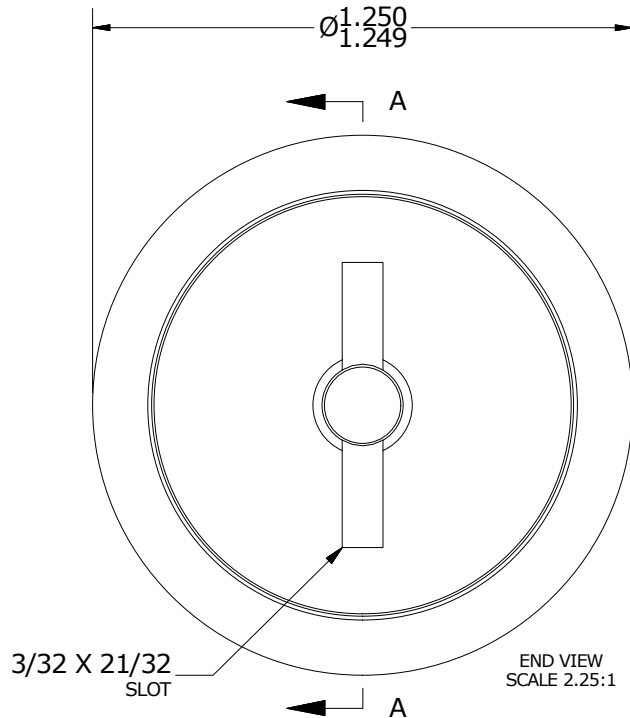
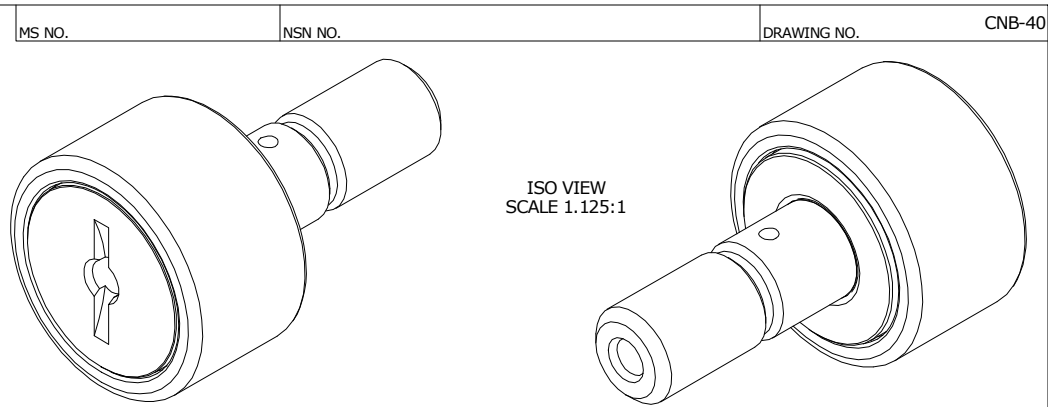

MATERIAL NOTES:

- OUTER RING - BEARING STEEL, HEAT TREATED
- STUD - BEARING STEEL, ZONE HARDENED
- NEEDLE ROLLER(S) - BEARING STEEL, HEAT TREATED
- WASHER - BEARING STEEL, HEAT TREATED

CUSTOMER PART#	XX = ± .01 XXX = ± .005 XXXX = ± .0005 ANGLES = ± 1' INCH [METRIC] FRACTION = ± 1/32
----------------	---

CARTER MANUFACTURING IS NOT RESPONSIBLE FOR TYPOGRAPHICAL ERRORS

CARTER MANUFACTURING CO., INC.
GRAND HAVEN, MICHIGAN 49417

ENGINEERING CHANGE ORDER NOTE

REVISION		PART NAME: ASSEMBLY			PRODUCT TYPE: CNB	
B	AUTHOR BY HG	DRAWN BY JAF	CHK'D BY MD	SALES KR	MATERIAL NOTED	
REVISION BY SGW	DATE 9/21/2015	DATE 6/28/2006	DATE 8/4/2015	DATE 9/21/2015	SHEET 1 OF 2	