

ISO VIEWS
SCALE 1.375 : 1

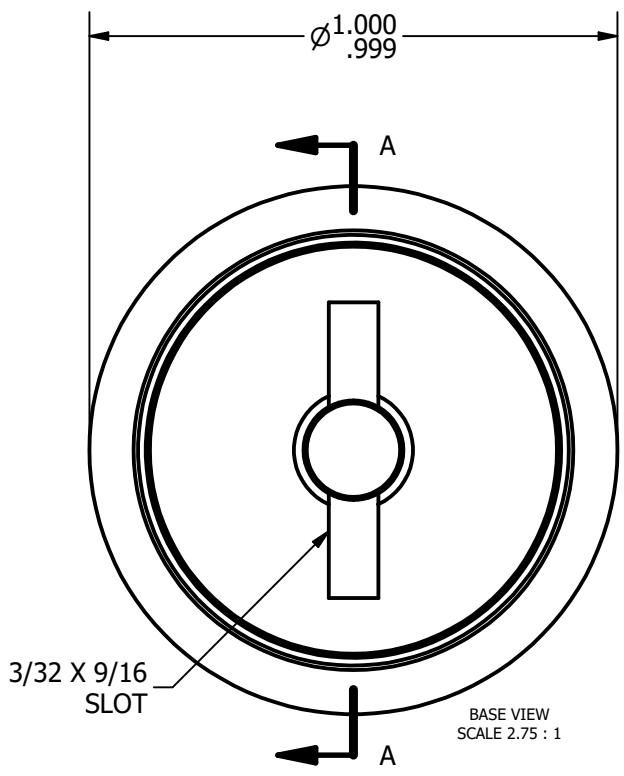

BASE VIEW
SCALE 2.75 : 1

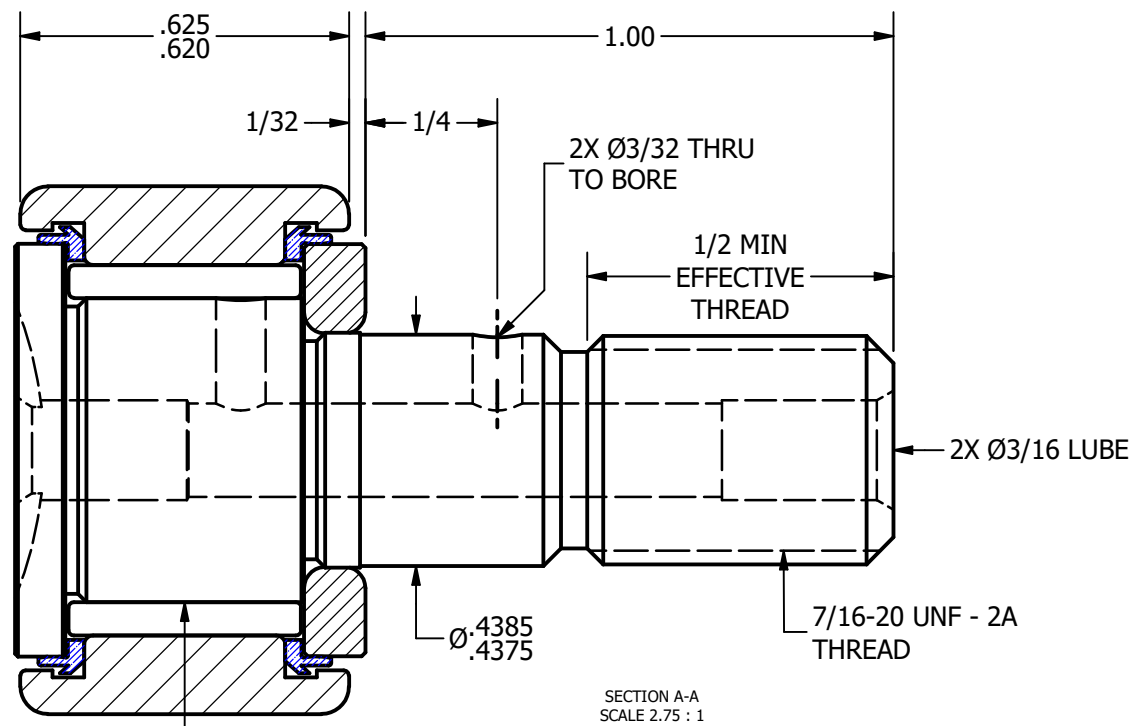

SECTION A-A
SCALE 2.75 : 1

MATERIAL NOTES:
 OUTER RACE - BEARING STEEL, HEAT TREATED
 STUD - BEARING STEEL, ZONE HARDENED
 NEEDLE ROLLERS - BEARING STEEL, HEAT TREATED
 WASHER - COLD ROLLED STEEL, HEAT TREATED
 SEALS - SYNTHETIC

CUSTOMER PART#	.XX = ± .01 .XXX = ± .005 .XXXX = ± .0005 ANGLES = ± 1' INCH [METRIC] FRACTION = ± 1/32
CHANGE NOTE:	

CARTER MANUFACTURING IS NOT RESPONSIBLE FOR TYPOGRAPHICAL ERRORS

REVISION	
D	AUTHOR. BY
DB	RAM
REV. BY	DATE
SGW	4/24/2013

CARTER MANUFACTURING CO., INC.
GRAND HAVEN, MICHIGAN 49417

PART NAME: ASSEMBLY		SHEET 1 OF 2			
	DRAWN BY	CHK'D BY	SALES	MATERIAL	
	MD	KPR	NOTED		
	DATE	DATE	DATE	DRAWING NO.	
	11/3/1997	4/24/2013	5/13/2008	CNB-32-S	