

LOAD RATINGS	
RATING	Lbs
RADIAL BASIC DYNAMIC	75,380
MAXIMUM STATIC CAPACITY	106,930

NOTES:  
 1. BEARING IS PACKED WITH LITHIUM BASED #2 WEIGHT GREASE  
 2. ALL EXPOSED SURFACES HAVE BLACK OXIDE

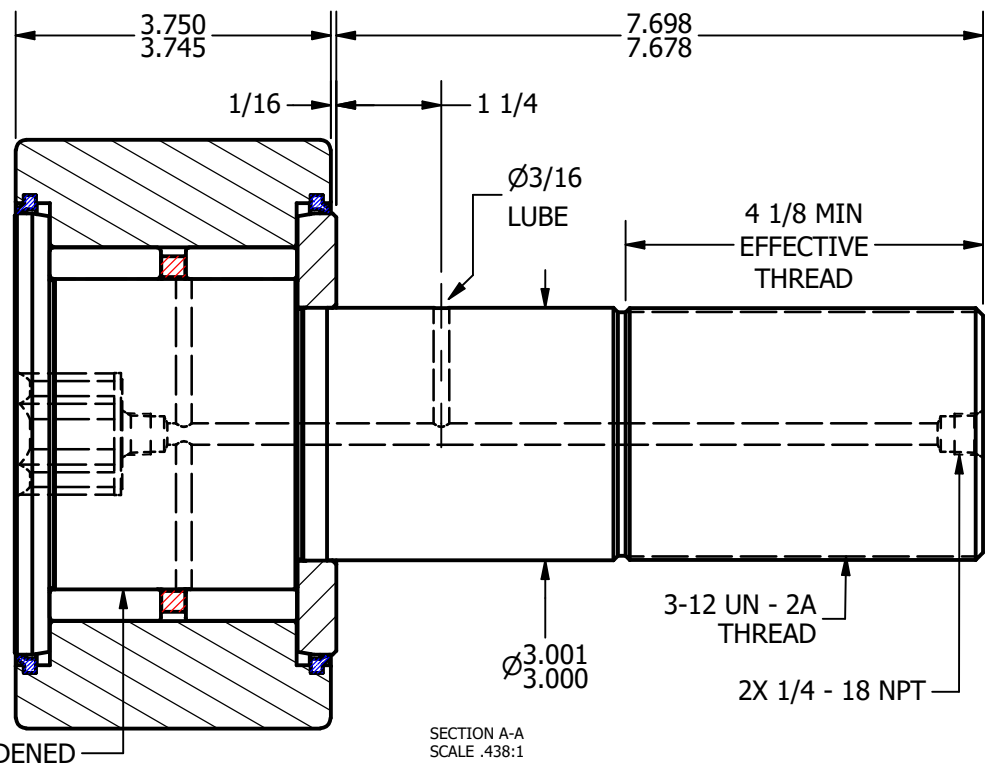
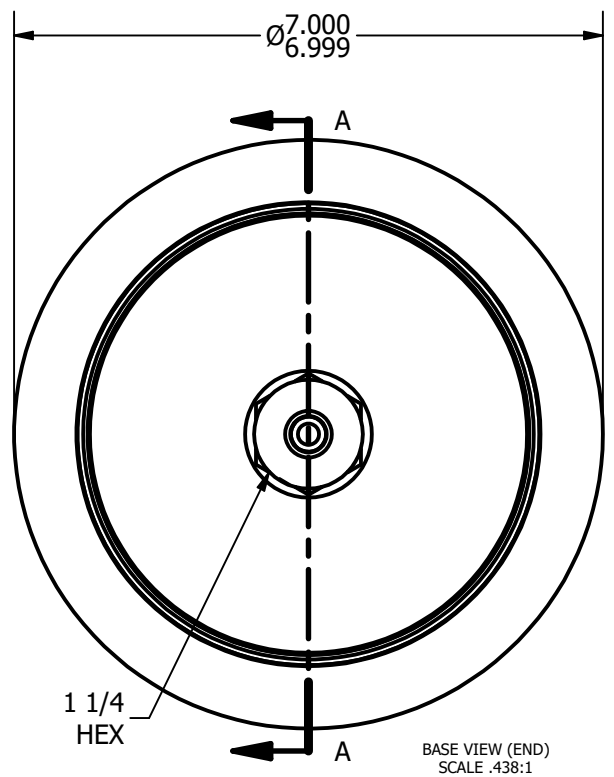
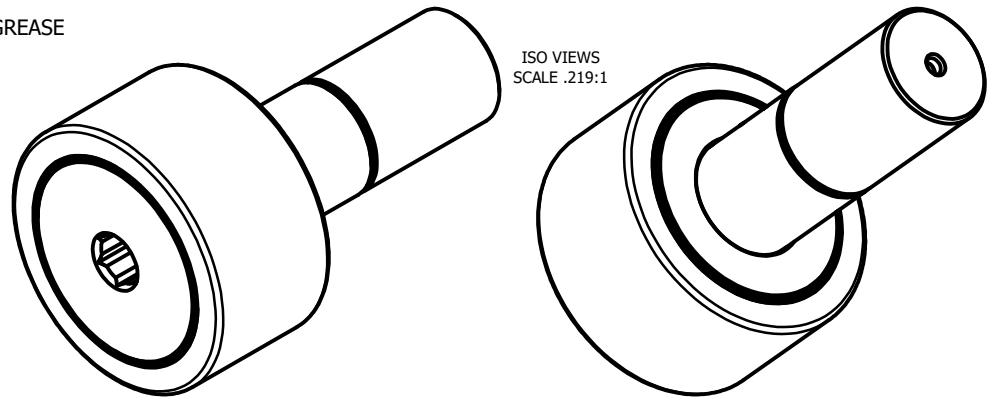

**MATERIAL NOTES:**  
 OUTER RACE - BEARING STEEL, HEAT TREATED  
 STUD - BEARING STEEL, ZONE HARDENED  
 NEEDLE ROLLER - BEARING STEEL, HEAT TREATED  
 SPACER - BEARING STEEL, HEAT TREATED  
 WASHER - COLD ROLLED STEEL, HEAT TREATED  
 SEAL - SYNTHETIC

CUSTOMER PART#	.XX = ± .01 .XXX = ± .005 .XXXX = ± .0005 ANGLES = ± 1' INCH [METRIC]
CHANGE NOTE:	

CARTER MANUFACTURING IS NOT RESPONSIBLE FOR TYPOGRAPHICAL ERRORS	
REVISION	
<b>B</b>	<b>AUTHOR. BY</b> DB
<b>REV. BY</b> SGW	<b>DATE</b> 10/5/2010

<b>CARTER MANUFACTURING CO., INC.</b>					
GRAND HAVEN, MICHIGAN 49417					
PART NAME: ASSEMBLY			SHEET 1 OF 2		
<b>SALES</b>	<b>MATERIAL</b>	<b>CHK'D BY</b>	<b>DRAWN BY</b>	<b>AUTHOR. BY</b>	<b>REV. BY</b>
KR	NOTED	MD	JAF	DB	SGW
<b>DATE</b>	<b>DATE</b>	<b>DATE</b>	<b>DATE</b>	<b>DATE</b>	<b>DATE</b>
10/5/2010	10/5/2010	10/5/2010	7/18/2006	10/5/2010	10/5/2010
<b>DRAWING NO.</b>		<b>CNB-224-SB</b>			