

- NOTES:**  
 1. BEARING IS PACKED WITH GREASE  
 2. ALL EXPOSED SURFACES ARE BLACK OXIDED

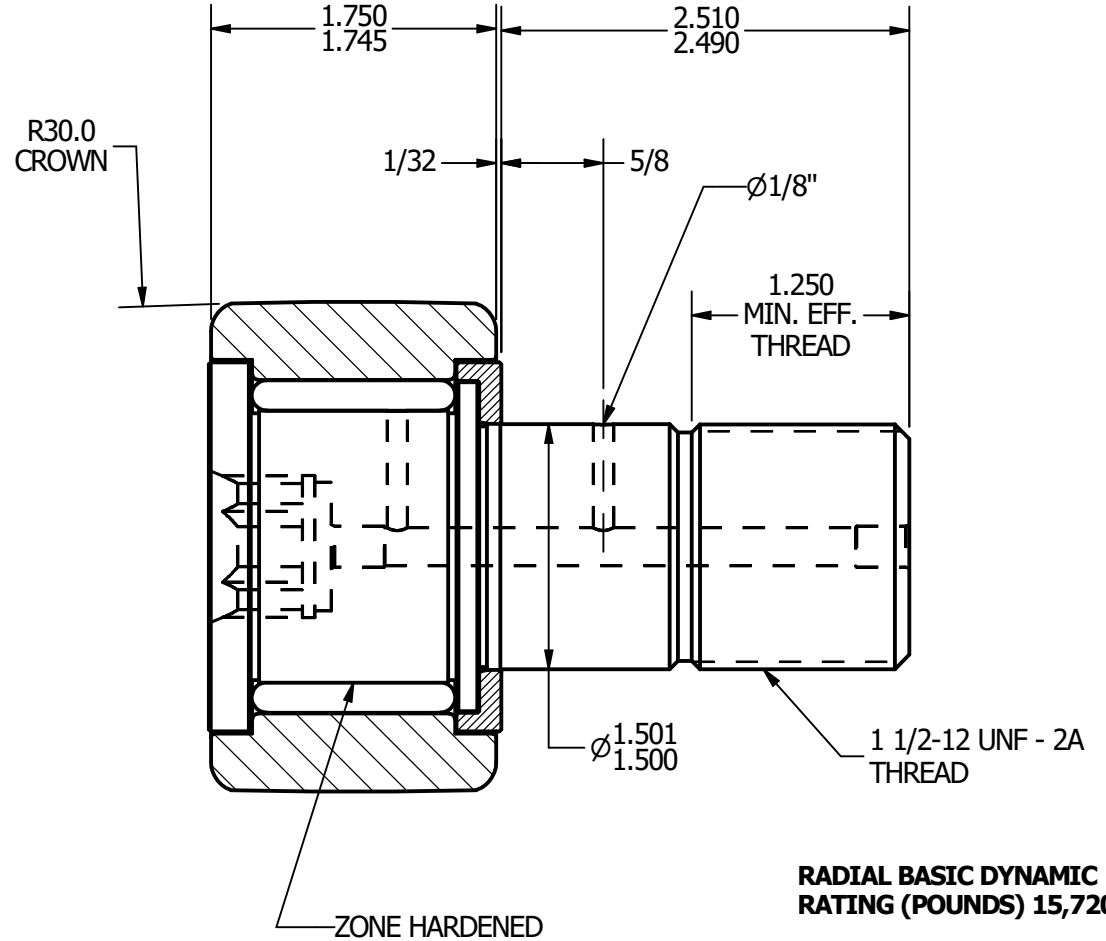
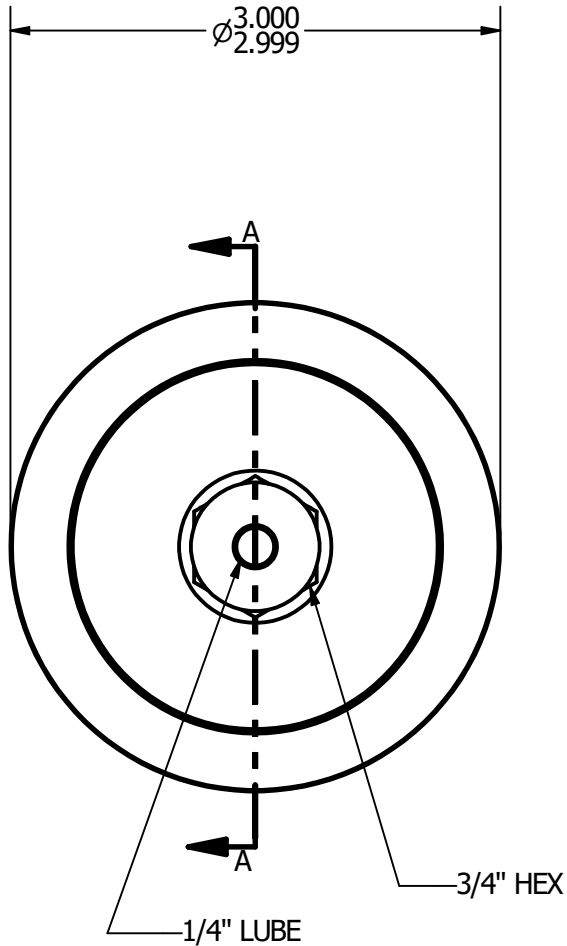
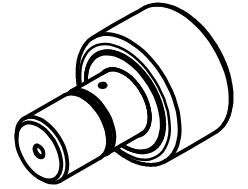

**RADIAL BASIC DYNAMIC RATING (POUNDS) 15,720**

**MAXIMUM STATIC CAPACITY (POUNDS) 49,820**

**MATERIAL NOTES:**  
 OUTER - BEARING STEEL, HEAT TREATED  
 STUD - BEARING STEEL, ZONE HARDENED  
 ROLLER - BEARING STEEL, HEAT TREATED  
 WASHER - COLD ROLLED STEEL, HEAT TREATED

CUSTOMER PART#  
 .XX = ± .01  
 .XXX = ± .005  
 .XXXX = ± .0005  
 ANGLES = ± 1'  
 INCH [METRIC]

CARTER MANUFACTURING IS NOT RESPONSIBLE FOR TYPOGRAPHICAL ERRORS

**CARTER MANUFACTURING CO., INC.**  
 GRAND HAVEN, MICHIGAN 49417

CHANGE NOTE:

<b>A</b>	AUTHOR. BY	DRAWN BY	CHK'D BY	SALES	MATERIAL
	JGV	JAF	JGV	KPR	NOTED
	REV. BY	DATE	DATE	DATE	DRAWING NO.
	JAF	7/10/2006	7/10/2006	7/10/2006	CCNBH-96-B

REVISION		PART NAME: Assembly			SHEET 1 OF 2
<b>A</b>	AUTHOR. BY	DRAWN BY	CHK'D BY	SALES	MATERIAL
	JGV	JAF	JGV	KPR	NOTED
	REV. BY	DATE	DATE	DATE	DRAWING NO.
	JAF	7/10/2006	7/10/2006	7/10/2006	CCNBH-96-B