

LOAD RATINGS		
RATING	lbf	Newtons
RADIAL BASIC DYNAMIC	8,090	35,896
MAXIMUM STATIC CAPACITY	21,140	94,035

MS NO.	NSN NO.	DRAWING NO.
--------	---------	-------------

RECOMMENDED MOUNTING HOLE Ø		
Limit	Inch	mm
MIN	1.1250	28.5750
MAX	1.1255	28.5877

- NOTES:
- BEARING IS PACKED WITH NLGI GRADE 2, LITHIUM BASED GREASE (UNLESS OTHERWISE SPECIFIED)
  - ALL EXPOSED STEEL SURFACES HAVE BLACK OXIDE
  - LIMITING SPEED:
    - A. GREASE = 1,400 RPM

MAXIMUM CLAMPING TORQUE		
Thread Type	Inch Lbs	Nm
DRY	2,800	316
LUBRICATED	1,400	158

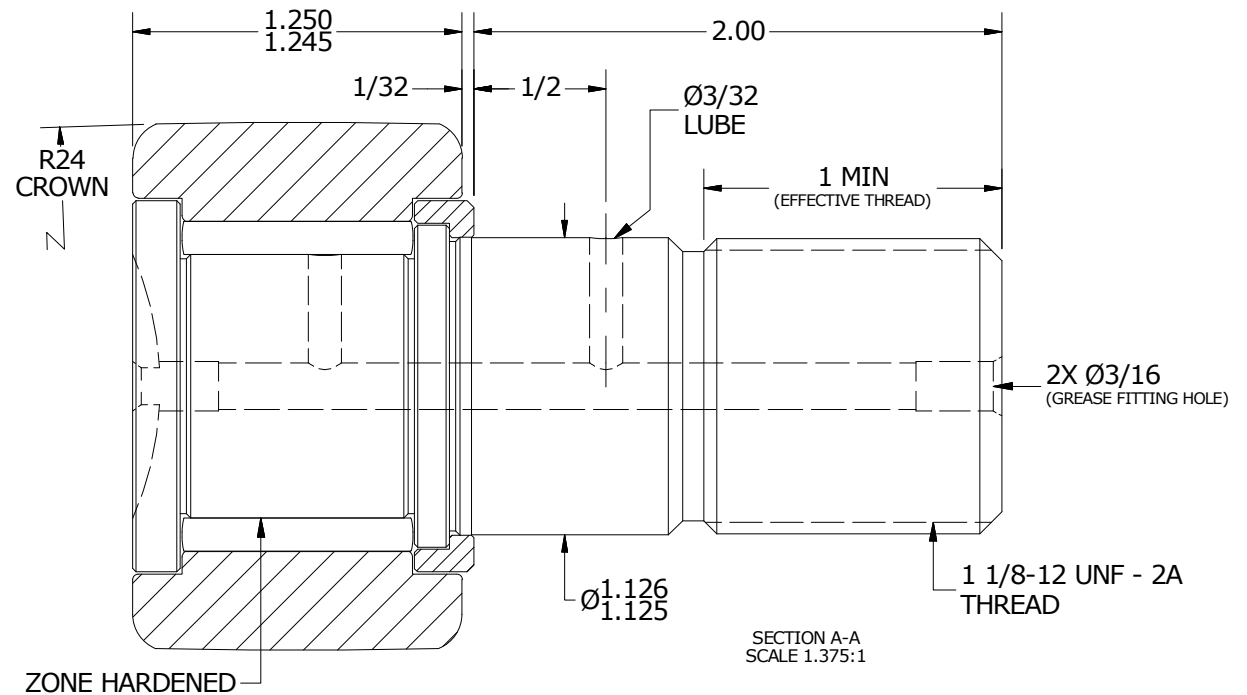
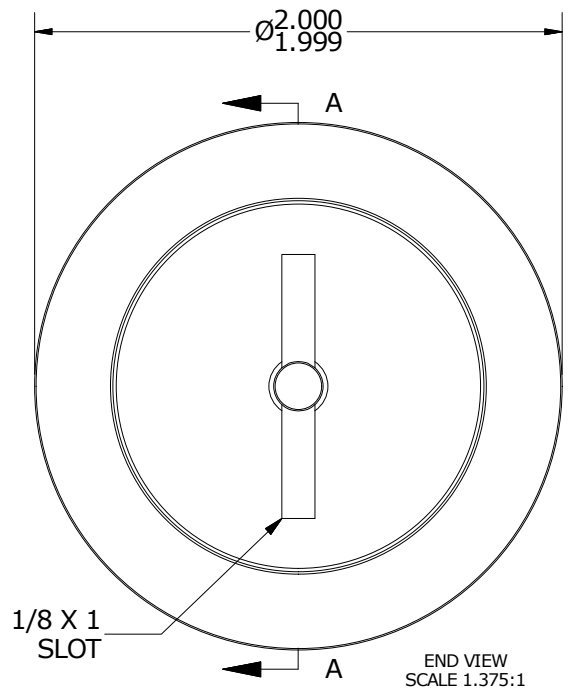
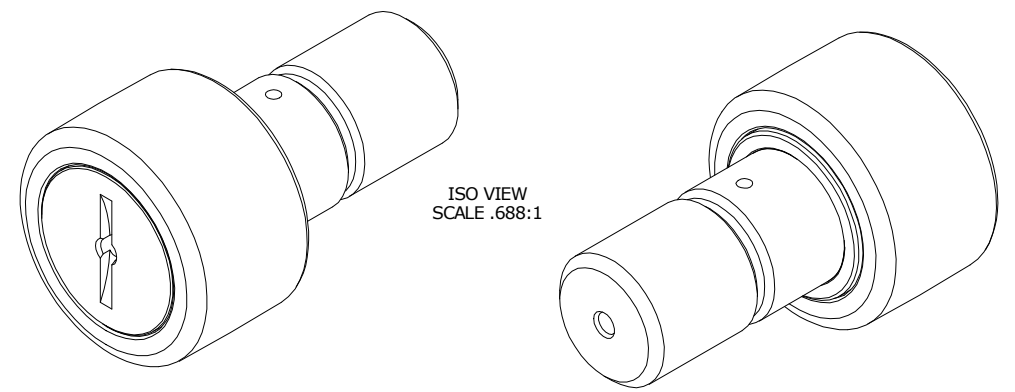

MATERIAL NOTES:

OUTER RING - BEARING STEEL, HEAT TREATED  
 STUD - BEARING STEEL, ZONE HARDENED  
 NEEDLE ROLLER(S) - BEARING STEEL, HEAT TREATED  
 WASHER - BEARING STEEL, HEAT TREATED

CUSTOMER PART#	XX = ± .01 XXX = ± .005 XXXX = ± .0005 ANGLES = ± 1' INCH [METRIC] FRACTION = ± 1/32
----------------	---

CARTER MANUFACTURING IS NOT RESPONSIBLE FOR TYPOGRAPHICAL ERRORS

**CARTER MANUFACTURING CO., INC.**  
 GRAND HAVEN, MICHIGAN 49417

ENGINEERING CHANGE ORDER NOTE	
REVISION BY	DATE
JLB	8/1/2018

REVISION	
<b>B</b>	AUTHOR BY
	HG
REVISION BY	DATE
JLB	8/1/2018

PART NAME: ASSEMBLY				PRODUCT TYPE: CNB	
DRAWN BY	CHK'D BY	SALES	MATERIAL		
EMD	MD	KR	NOTED		
DATE	DATE	DATE	DATE	DATE	SHEET
7/12/2006	8/1/2018	8/2/2018			1 OF 2