

- NOTES:**  
 1. BEARING IS PACKED WITH GREASE  
 2. ALL EXPOSED SURFACES ARE BLACK OXIDED

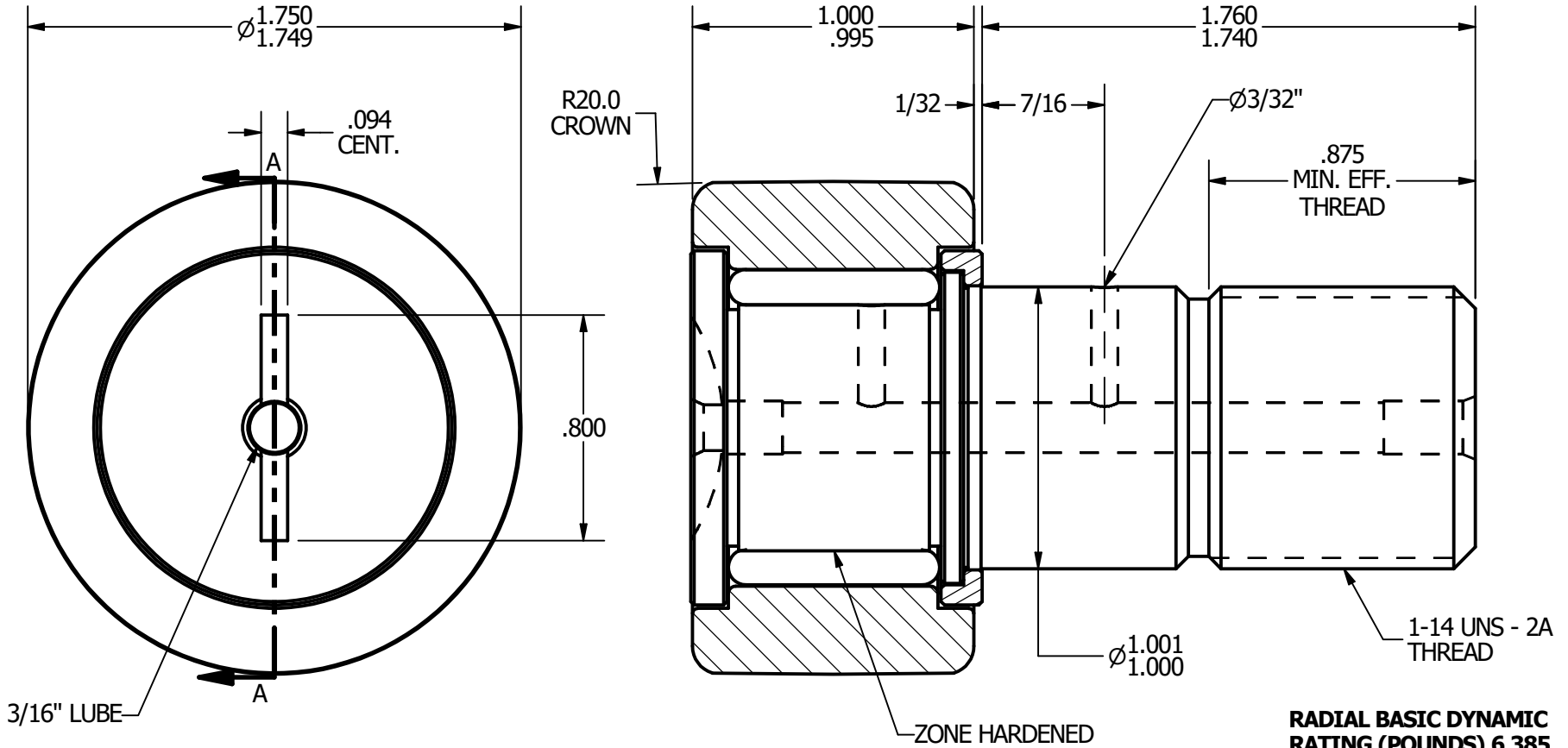
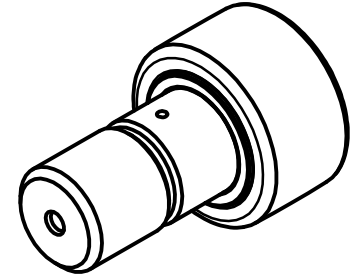

**RADIAL BASIC DYNAMIC RATING (POUNDS) 6,385**

**MAXIMUM STATIC CAPACITY (POUNDS) 15,840**

**MATERIAL NOTES:**

- OUTER - BEARING STEEL, HEAT TREATED**  
**STUD - BEARING STEEL, ZONE HARDENED**  
**ROLLER - BEARING STEEL, HEAT TREATED**  
**WASHER - COLD ROLLED STEEL, HEAT TREATED**

CUSTOMER PART#

.XX =  $\pm .01$   
 .XXX =  $\pm .005$   
 .XXXX =  $\pm .0005$   
 ANGLES =  $\pm 1'$   
 INCH [METRIC]

CARTER MANUFACTURING IS NOT RESPONSIBLE FOR TYPOGRAPHICAL ERRORS

**CARTER MANUFACTURING CO., INC.**

GRAND HAVEN, MICHIGAN 49417

REVISION

PART NAME: ASSEMBLY

SHEET 1 OF 2

CHANGE NOTE:

**A**

REV. BY

AUTHOR. BY

DRAWN BY

CHK'D BY

SALES

MATERIAL

JGV

EMD

JGV

KPR

NOTED

DATE

DATE

DATE

DATE

DRAWING NO.

7/13/2006

7/13/2006

7/13/2006

7/12/2006

CCNBH-56