

LOAD RATINGS		
RATING	lbf	Newtons
RADIAL BASIC DYNAMIC	6,385	28,402
MAXIMUM STATIC CAPACITY	15,840	70,460

- NOTES:
1. BEARING IS PACKED WITH NLGI GRADE 2, LITHIUM BASED GREASE UNLESS OTHERWISE SPECIFIED
 2. ALL EXPOSED SURFACES HAVE BLACK OXIDE
 3. CUSTOM LASER ETCHING AVAILABLE UPON REQUEST
 4. LIMITING SPEED:
 - A. GREASE = 2,200 RPM

RECOMMENDED MOUNTING HOLE Ø		
Limit	Inch	mm
MIN	1.0000	25.4000
MAX	1.0005	25.4127

MAXIMUM CLAMPING TORQUE		
Thread Type	Inch lbf	Nm
DRY	2,250	254
LUBRICATED	1,125	127

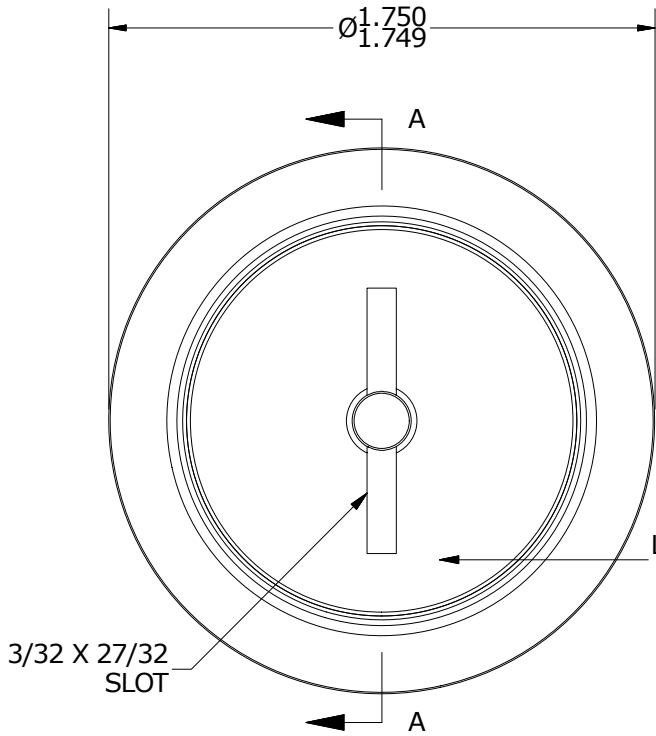
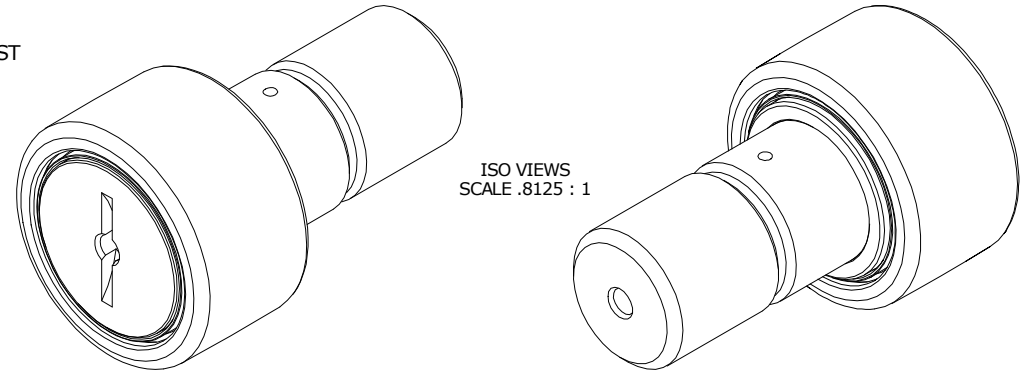

END VIEW
SCALE 1.625 : 1

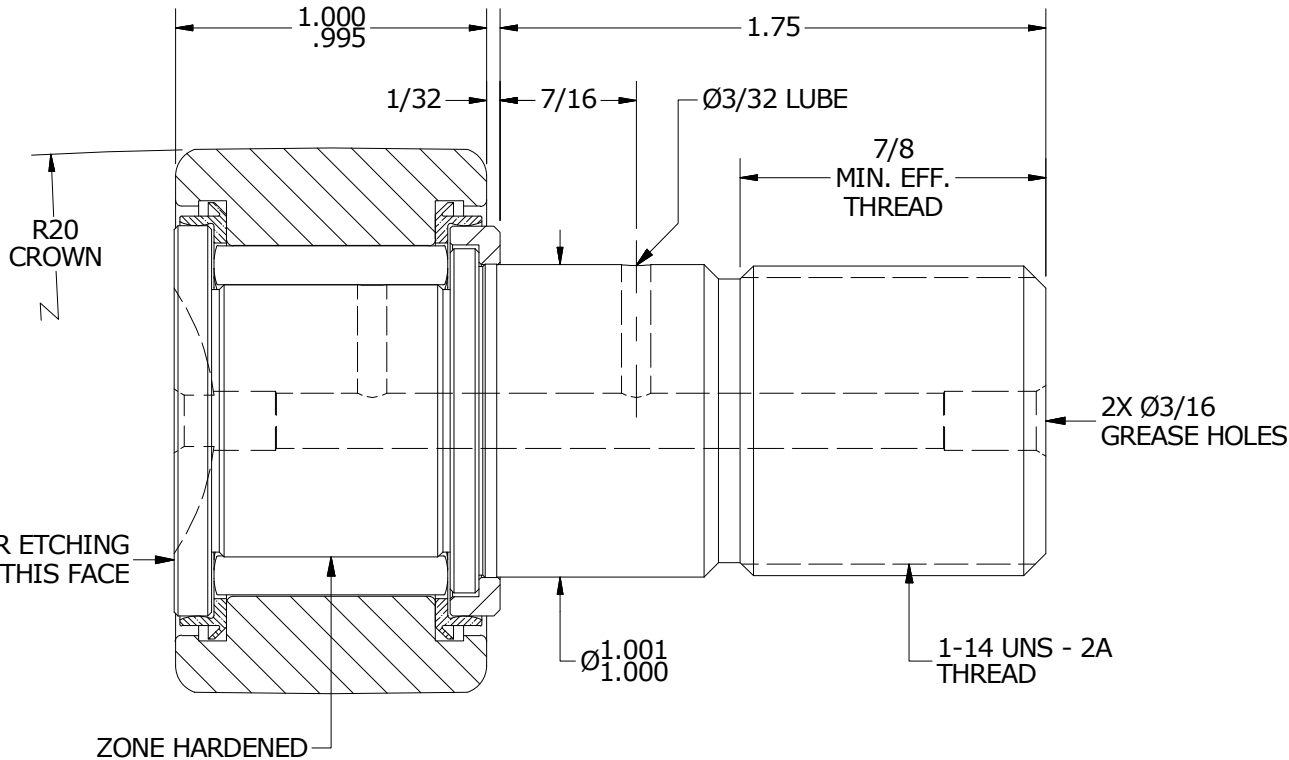

SECTION A-A
SCALE 1.625 : 1

MATERIAL NOTES:

- OUTER RING - BEARING STEEL, HEAT TREATED
- STUD - BEARING STEEL, ZONE HARDENED
- NEEDLE ROLLERS - BEARING STEEL, HEAT TREATED
- WASHER - BEARING STEEL, HEAT TREATED
- SEALS - SYNTHETIC

CUSTOMER PART#

XX = ± .01
XXX = ± .005
XXXX = ± .0005
ANGLES = ± 1'
INCH [METRIC]
FRACTION = ± 1/32

CARTER MANUFACTURING IS NOT RESPONSIBLE FOR TYPOGRAPHICAL ERRORS

CARTER MANUFACTURING CO., INC.

GRAND HAVEN, MICHIGAN 49417

ENGINEERING CHANGE ORDER NOTE

REVISION

PART NAME: ASSEMBLY

PRODUCT TYPE: CCNBH

B

AUTHOR BY

DRAWN BY

CHK'D BY

SALES

MATERIAL

DATE

DATE

DATE

DATE

SHEET

MD

8/13/2019

7/13/2006

8/12/2019

7/12/2006

1 OF 2