

LOAD RATINGS		
RATING	Lbs	Newtons
RADIAL BASIC DYNAMIC	1,660	7,384
MAXIMUM STATIC CAPACITY	4,130	18,371

MS NO. _____ NSN NO. _____ DRAWING NO. CCNBH-28-B

RECOMMENDED MOUNTING HOLE Ø		
Limit	Inch	mm
MIN	.4375	11.1125
MAX	.4380	11.1252

- NOTES:
1. BEARING IS PACKED WITH NLGI GRADE 2, LITHIUM BASED GREASE (UNLESS OTHERWISE SPECIFIED)
 2. ALL EXPOSED STEEL SURFACES HAVE BLACK OXIDE
 3. LIMITING SPEED:
 - A. GREASE = 5,400 RPM

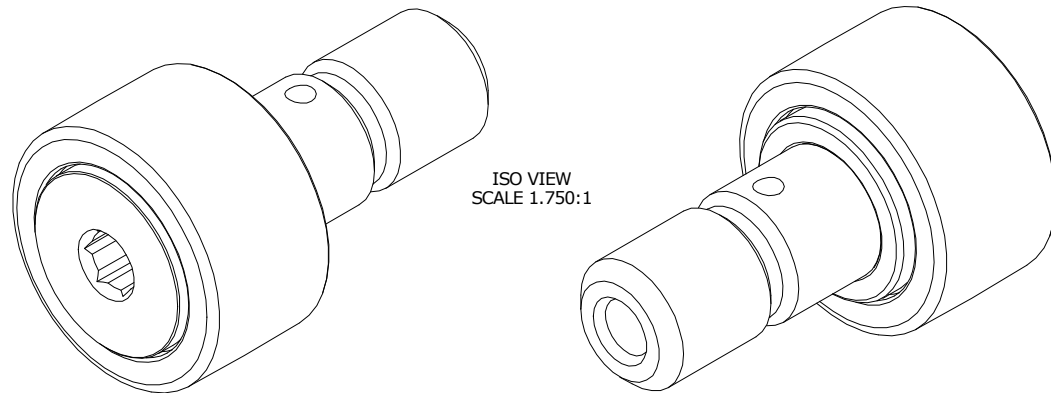

MAXIMUM CLAMPING TORQUE		
Thread Type	Inch Lbs	Nm
DRY	250	28.2
LUBRICATED	125	14.1

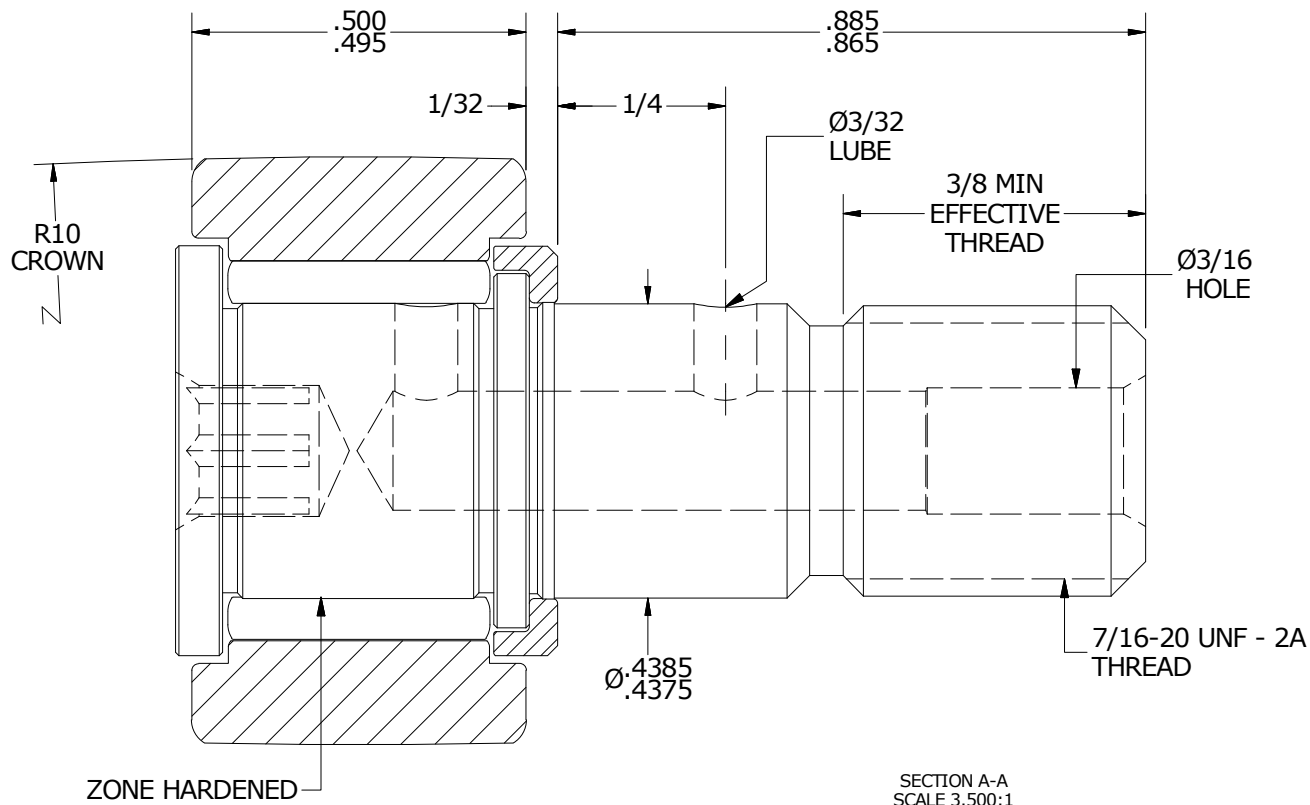
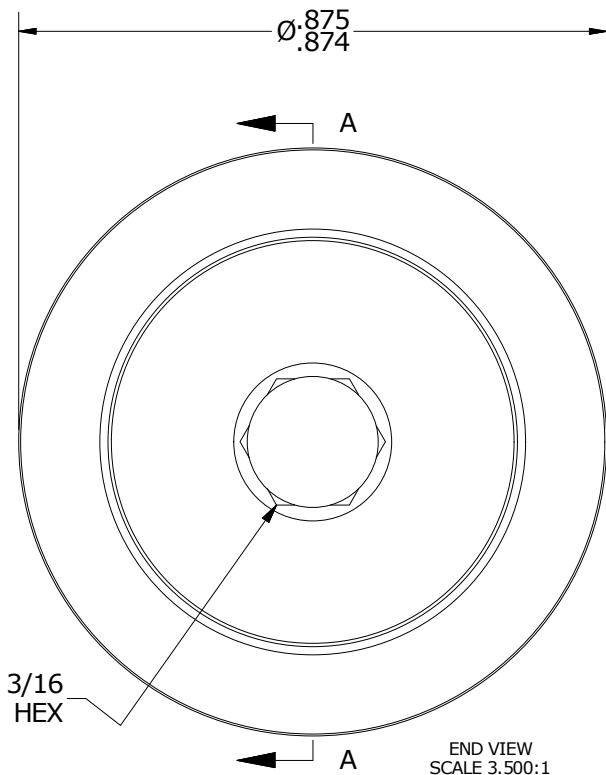

MATERIAL NOTES:

- OUTER RING - BEARING STEEL, HEAT TREATED
- STUD - BEARING STEEL, ZONE HARDENED
- NEEDLE ROLLER(S) - BEARING STEEL, HEAT TREATED
- WASHER - BEARING STEEL, HEAT TREATED

CUSTOMER PART#

XX = ± .01
 XXX = ± .005
 XXXX = ± .0005
 ANGLES = ± 1'
 INCH [METRIC]
 FRACTION = ± 1/32

CARTER MANUFACTURING IS NOT RESPONSIBLE FOR TYPOGRAPHICAL ERRORS

CARTER MANUFACTURING CO., INC.

GRAND HAVEN, MICHIGAN 49417

ENGINEERING CHANGE ORDER NOTE

REVISION

PART NAME: ASSEMBLY

B

AUTHOR BY
HG

DRAWN BY
EMD

CHK'D BY
MD

SALES
KR

MATERIAL
NOTED

REVISION BY
SGW

DATE
5/1/2017

DATE
6/22/2006

DATE
4/28/2017

DATE
5/5/2017

SHEET
1 OF 2