

LOAD RATINGS		
RATING	Lbs	Newtons
RADIAL BASIC DYNAMIC	1,660	7,384
MAXIMUM STATIC CAPACITY	4,130	18,371

MS NO. _____ NSN NO. _____ DRAWING NO. CCNBH-24

RECOMMENDED MOUNTING HOLE Ø		
Limit	Inch	mm
MIN	.4375	11.1125
MAX	.4380	11.1252

- NOTES:
- BEARING IS PACKED WITH NLGI GRADE 2, LITHIUM BASED GREASE (UNLESS OTHERWISE SPECIFIED)
 - ALL EXPOSED STEEL SURFACES HAVE BLACK OXIDE
 - LIMITING SPEED:
 - A. GREASE = 6,400 RPM

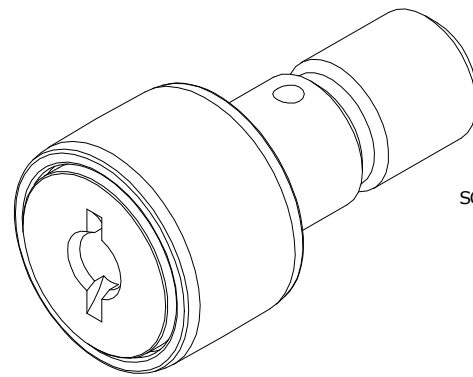

ISO VIEW
SCALE 1.750:1

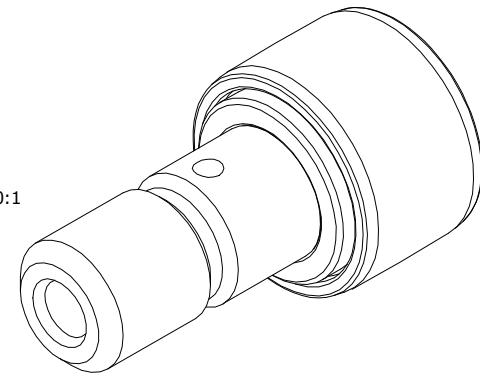

MAXIMUM CLAMPING TORQUE		
Thread Type	Inch Lbs	Nm
DRY	250	28.2
LUBRICATED	125	14.1

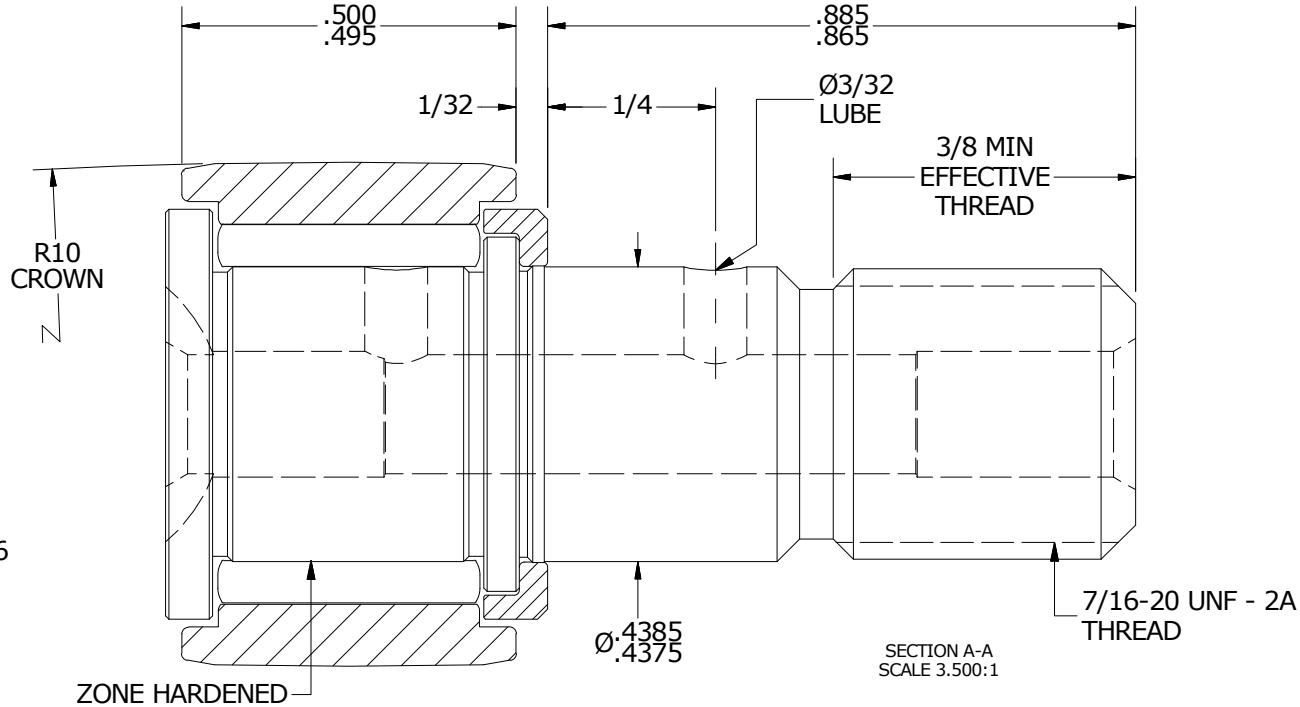
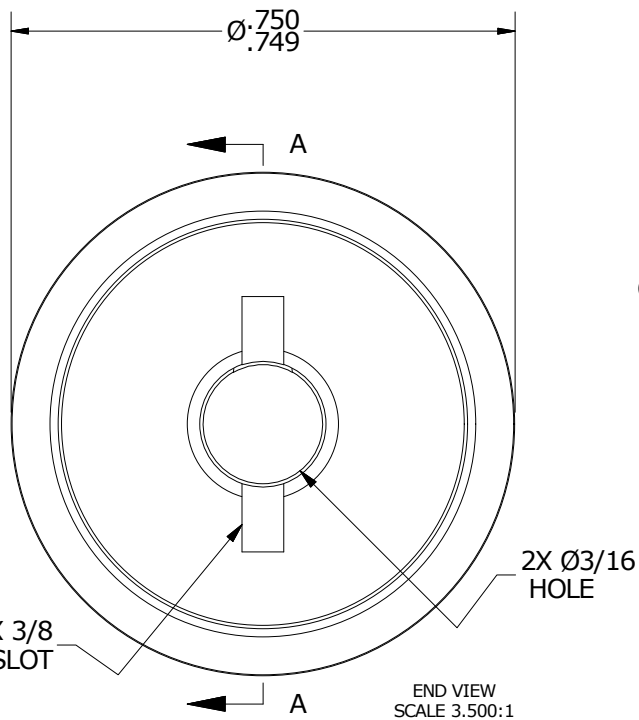

MATERIAL NOTES:

OUTER RING - BEARING STEEL, HEAT TREATED
 STUD - BEARING STEEL, ZONE HARDENED
 NEEDLE ROLLER(S) - BEARING STEEL, HEAT TREATED
 WASHER - BEARING STEEL, HEAT TREATED

CUSTOMER PART#

XX = ± .01
 XXX = ± .005
 XXXX = ± .0005
 ANGLES = ± 1'
 INCH [METRIC]
 FRACTION = ± 1/32

CARTER MANUFACTURING IS NOT RESPONSIBLE FOR TYPOGRAPHICAL ERRORS

CARTER MANUFACTURING CO., INC.

GRAND HAVEN, MICHIGAN 49417

ENGINEERING CHANGE ORDER NOTE

REVISION

PART NAME: ASSEMBLY

B

AUTHOR BY

DRAWN BY

CHK'D BY

SALES

MATERIAL

HG

EMD

MD

KR

NOTED

REVISION BY

DATE

DATE

DATE

DATE

SHEET

SGW

5/1/2017

6/22/2006

4/28/2017

5/5/2017

1 OF 2