

- NOTES:**
 1. BEARING IS PACKED WITH GREASE
 2. ALL EXPOSED SURFACES ARE BLACK OXIDED

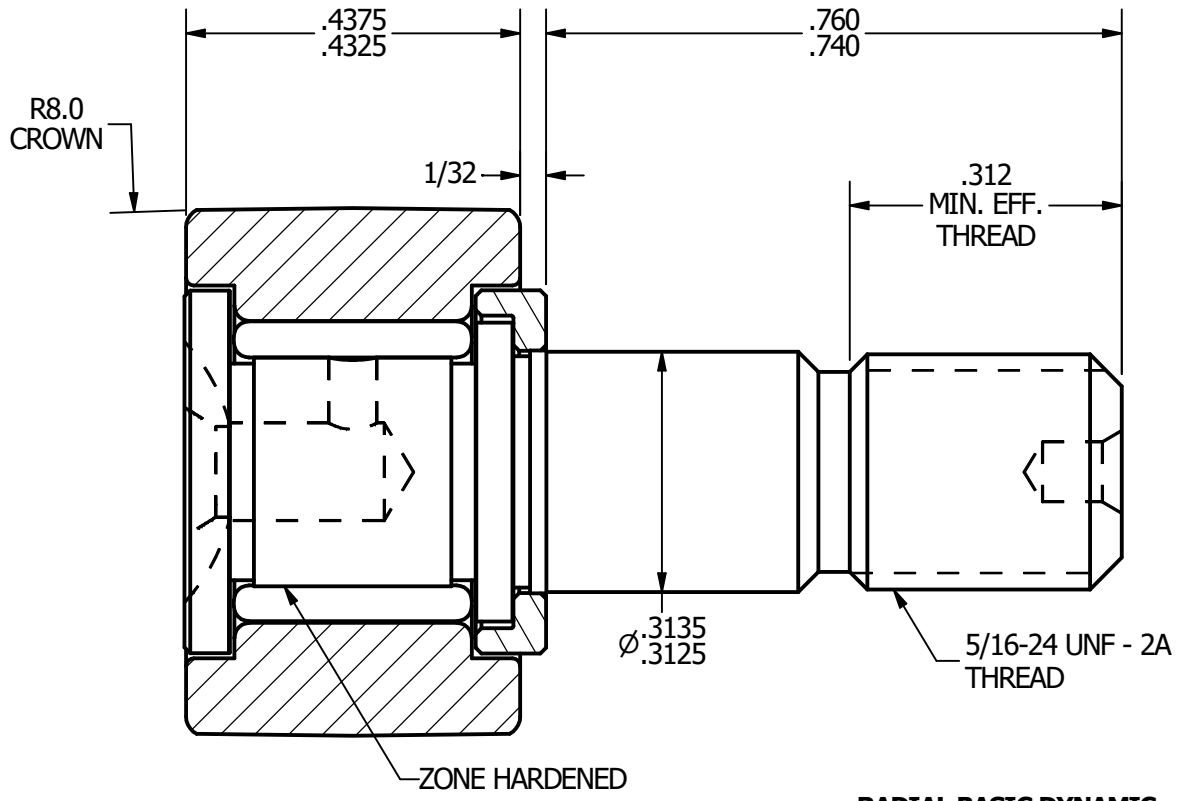
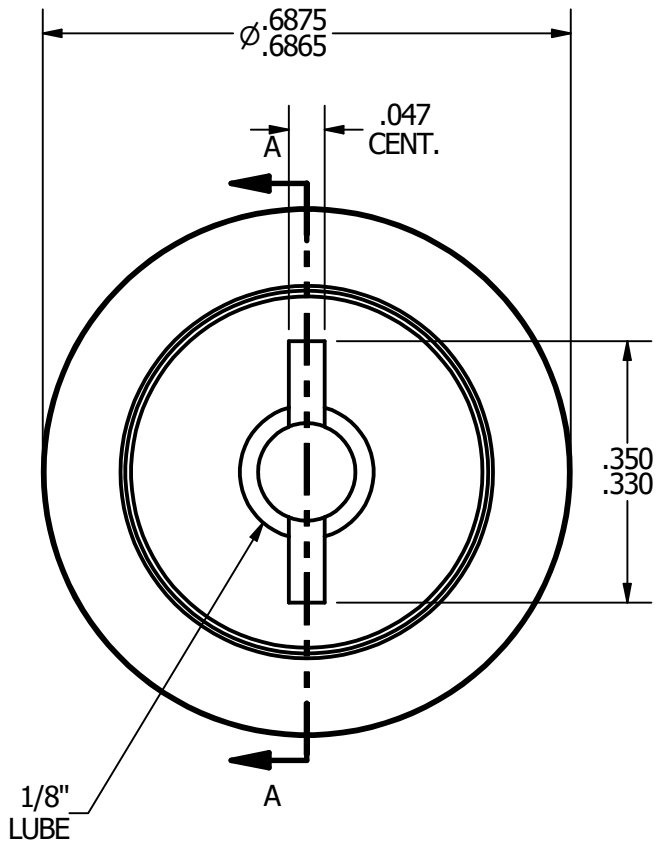
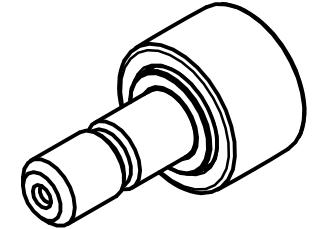

RADIAL BASIC DYNAMIC RATING (POUNDS) 955
MAXIMUM STATIC CAPACITY (POUNDS) 2480

MATERIAL NOTES:

OUTER - BEARING STEEL, HEAT TREATED
STUD - BEARING STEEL, ZONE HARDENED
ROLLER - BEARING STEEL, HEAT TREATED
WASHER - COLD ROLLED STEEL, HEAT TREATED

CUSTOMER PART#

.XX = ± .01
 .XXX = ± .005
 .XXXX = ± .0005
 ANGLES = ± 1'
 INCH [METRIC]

CHANGE NOTE:

CARTER MANUFACTURING IS NOT RESPONSIBLE FOR TYPOGRAPHICAL ERRORS

REVISION

A	AUTHOR. BY	DRAWN BY	CHK'D BY	SALES	MATERIAL
	JGV	EMD	JGV	KPR	NOTED
REV. BY	DATE	DATE	DATE	DATE	DRAWING NO.
EMD	6/19/2006	6/19/2006	6/19/2006	6/18/2006	CCNBH-22

CARTER MANUFACTURING CO., INC.
 GRAND HAVEN, MICHIGAN 49417

PART NAME: ASSEMBLY SHEET 1 OF 2