

LOAD RATINGS	
RATING	Lbs
RADIAL BASIC DYNAMIC [C]	680
MAXIMUM STATIC CAPACITY [Co]	1,580

NOTES:  
 1. BEARING IS PACKED WITH LITHIUM BASED #2 WEIGHT GREASE  
 2. ALL EXPOSED SURFACES HAVE BLACK OXIDE

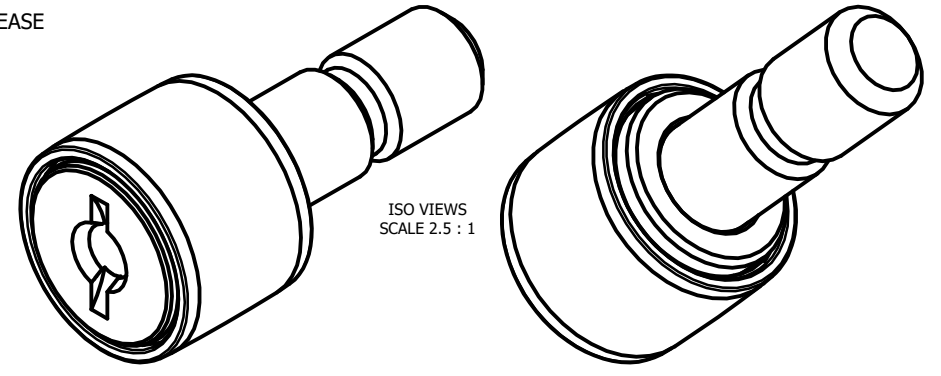

ISO VIEWS  
 SCALE 2.5 : 1

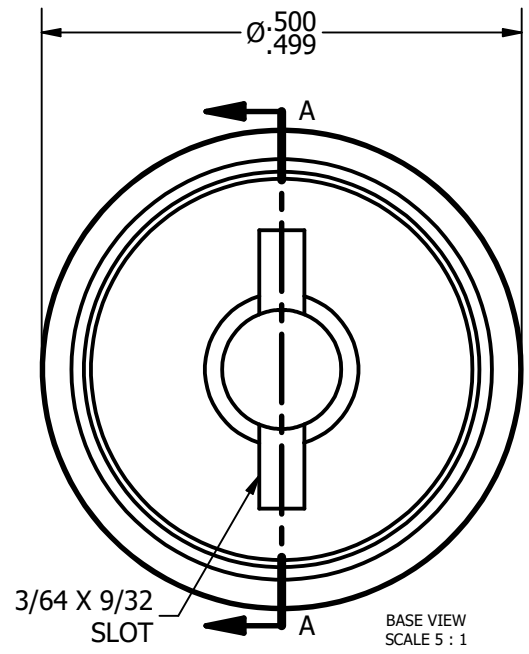

BASE VIEW  
 SCALE 5 : 1

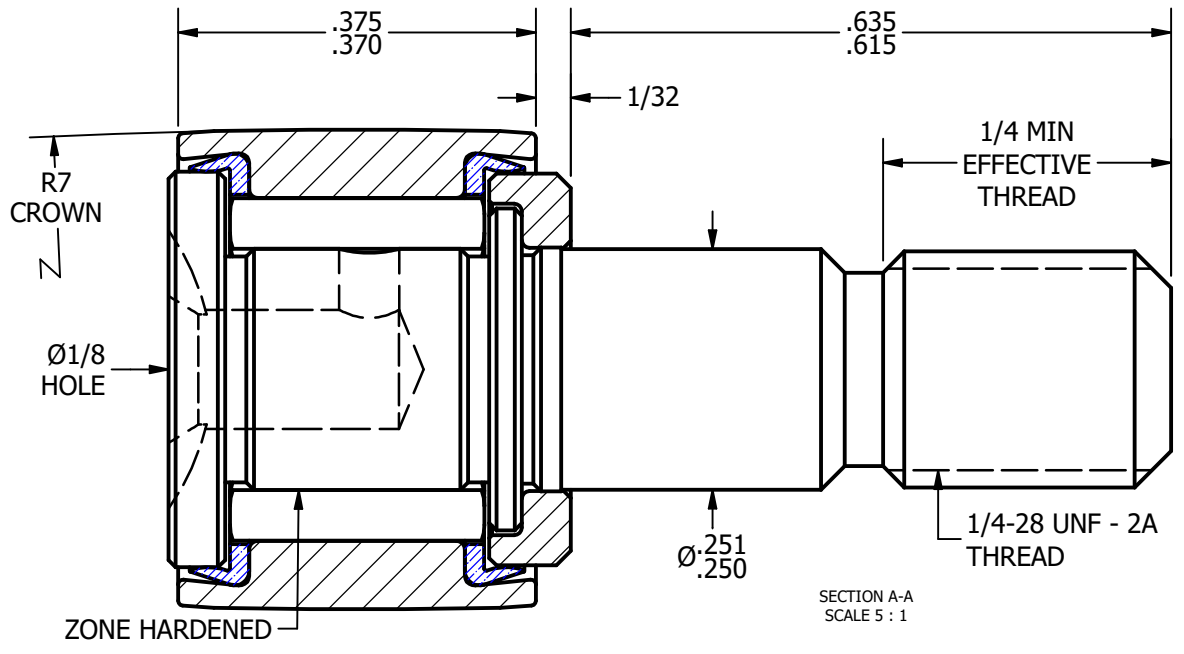

SECTION A-A  
 SCALE 5 : 1

**MATERIAL NOTES:**  
 OUTER RACE - BEARING STEEL, HEAT TREATED  
 STUD - BEARING STEEL, ZONE HARDENED  
 NEEDLE ROLLER - BEARING STEEL, HEAT TREATED  
 WASHER - COLD ROLLED STEEL, HEAT TREATED  
 SEAL - SYNTHETIC

CUSTOMER PART#	.XX = ± .01 .XXX = ± .005 .XXXX = ± .0005 ANGLES = ± 1' INCH [METRIC] FRACTION = ± 1/32
CHANGE NOTE:	

CARTER MANUFACTURING IS NOT RESPONSIBLE FOR TYPOGRAPHICAL ERRORS

REVISION	
<b>B</b>	<b>AUTHOR. BY</b> DB
<b>REV. BY</b> SGW	<b>DATE</b> 2/25/2011

**CARTER MANUFACTURING CO., INC.**  
 GRAND HAVEN, MICHIGAN 49417

PART NAME: ASSEMBLY		SHEET 1 OF 2			
<b>CHK'D BY</b> MD	<b>SALES</b> KR	<b>MATERIAL</b> NOTED			
<b>DATE</b> 2/25/2011	<b>DATE</b> 3/8/2011	<b>DRAWING NO.</b> CCNBH-16-S			