

- NOTES:**  
 1. BEARING IS PACKED WITH GREASE  
 2. ALL EXPOSED SURFACES ARE BLACK OXIDED

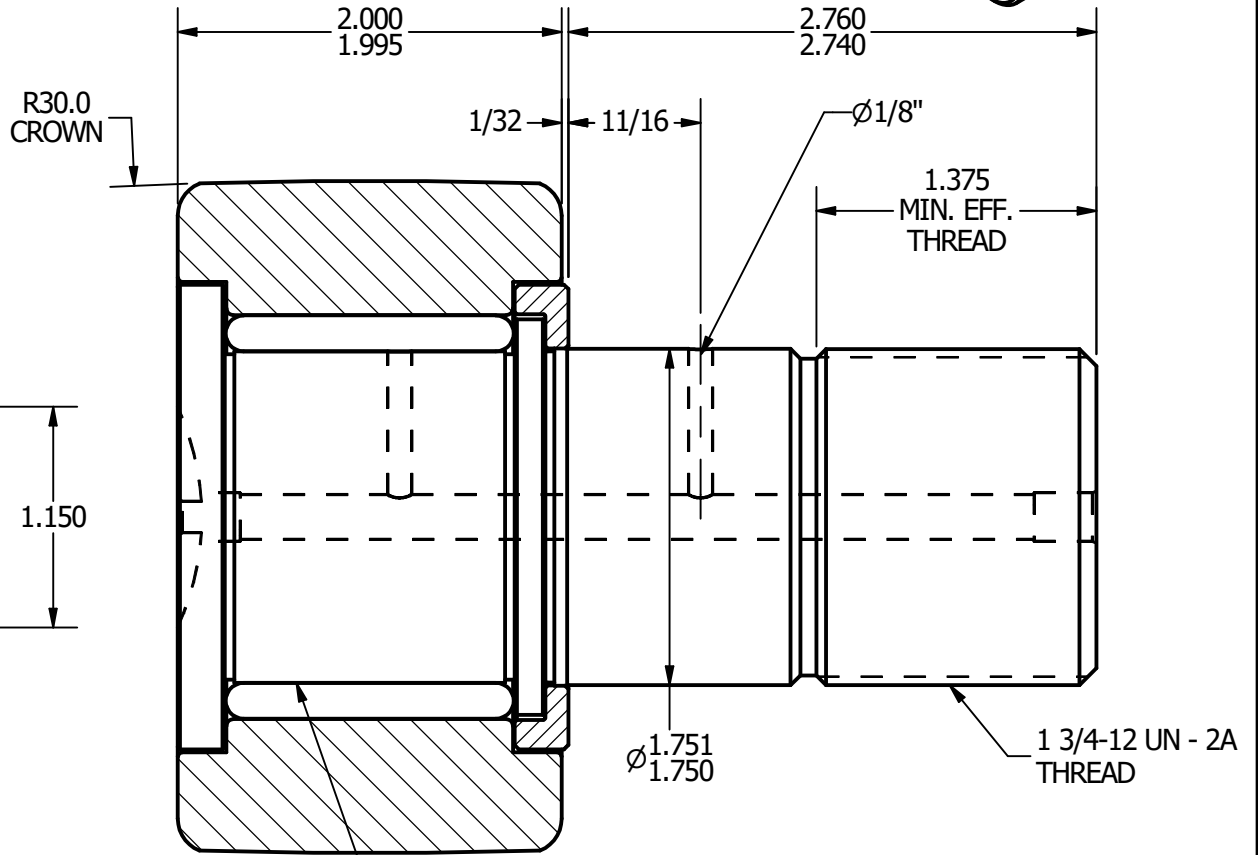
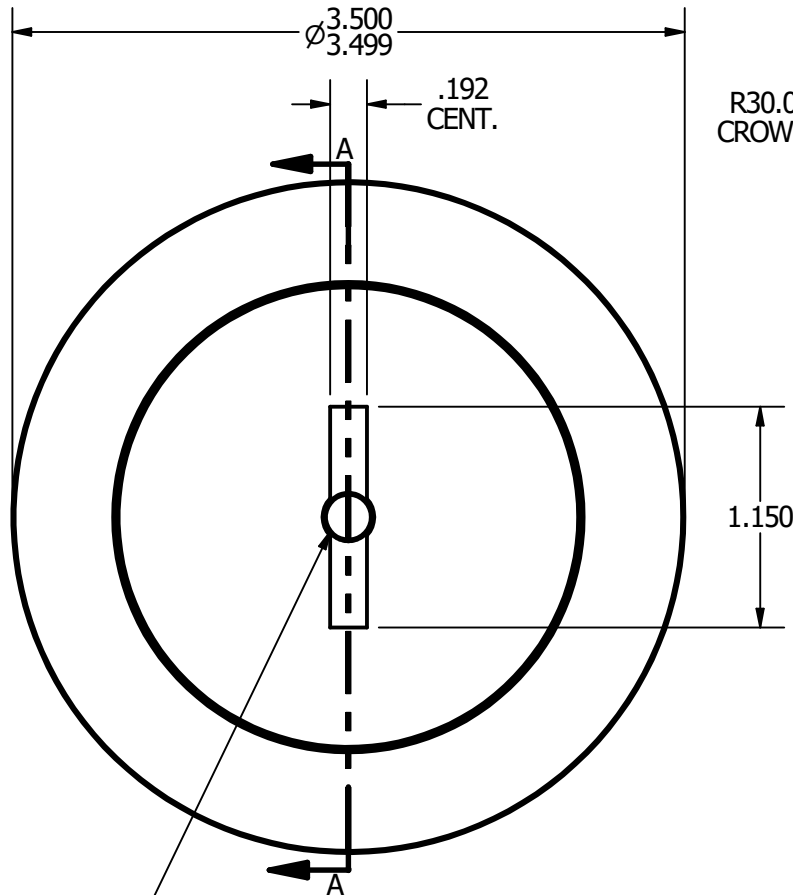
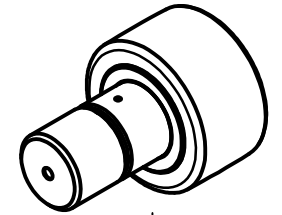

**RADIAL BASIC DYNAMIC RATING (POUNDS) 22,800**

**MAXIMUM STATIC CAPACITY (POUNDS) 63,250**

**MATERIAL NOTES:**

- OUTER - BEARING STEEL, HEAT TREATED**  
**STUD - BEARING STEEL, ZONE HARDENED**  
**ROLLER - BEARING STEEL, HEAT TREATED**  
**WASHER - COLD ROLLED STEEL, HEAT TREATED**

CUSTOMER PART#

.XX = ± .01  
 .XXX = ± .005  
 .XXXX = ± .0005  
 ANGLES = ± 1'  
 INCH [METRIC]

CARTER MANUFACTURING IS NOT RESPONSIBLE FOR TYPOGRAPHICAL ERRORS

**CARTER MANUFACTURING CO., INC.**

GRAND HAVEN, MICHIGAN 49417

REVISION

PART NAME: Assembly

SHEET 1 OF 2

CHANGE NOTE:

**A**

REV. BY

AUTHOR. BY

DRAWN BY

CHK'D BY

SALES

MATERIAL

JGV

EMD

JGV

KPR

NOTED

DATE

DATE

DATE

DATE

DRAWING NO.

EMD

7/7/2006

7/7/2006

7/7/2006

7/7/2006

CCNBH-112