

LOAD RATINGS		
RATING	lbf	Newtons
RADIAL BASIC DYNAMIC	8,090	35,986
MAXIMUM STATIC CAPACITY	10,570	47,018

MS NO. _____ NSN NO. _____ DRAWING NO. CCNBE-64

RECOMMENDED MOUNTING HOLE Ø		
Limit	Inch	mm
MIN	1.189	30.2006
MAX	1.191	30.2514

- NOTES:
1. BEARING IS PACKED WITH NLGI GRADE 2, LITHIUM BASED GREASE (UNLESS OTHERWISE SPECIFIED)
 2. ALL EXPOSED SURFACES HAVE BLACK OXIDE
 3. LIMITING SPEED:
 - A. GREASE = 1,400 RPM

MAXIMUM CLAMPING TORQUE		
Thread Type	Inch Lbs	Nm
DRY	1500	169.5
LUBRICATED	750	84.7

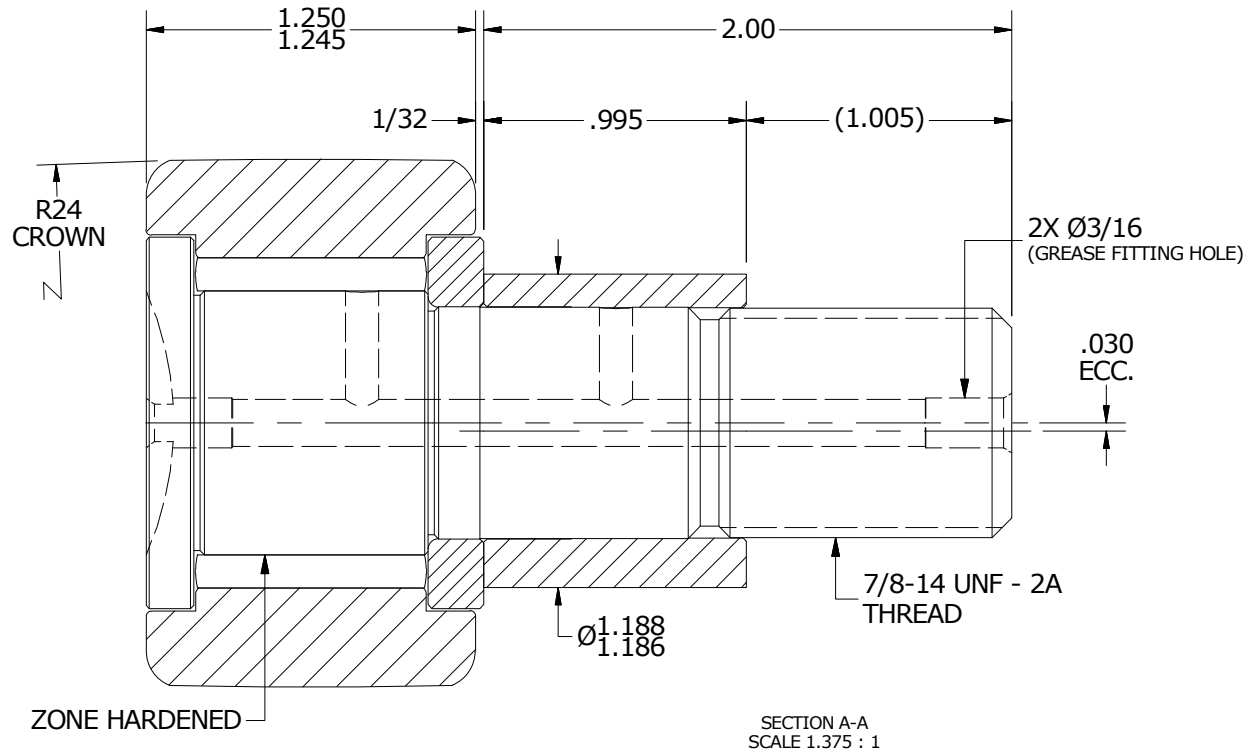
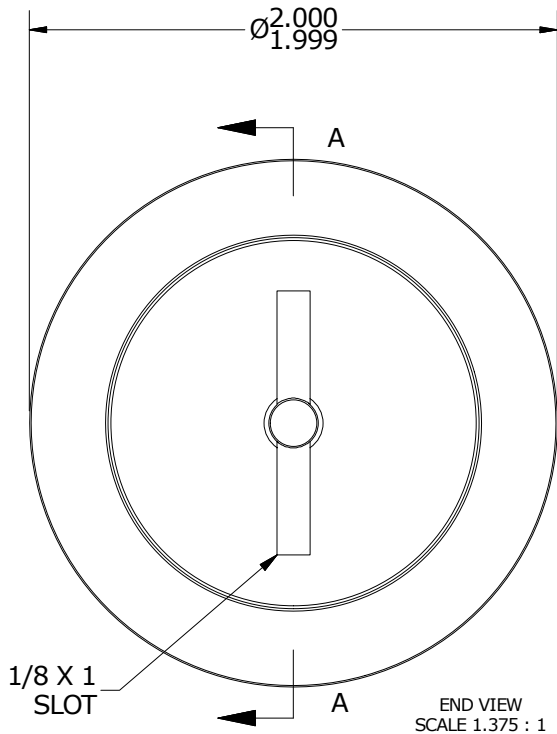
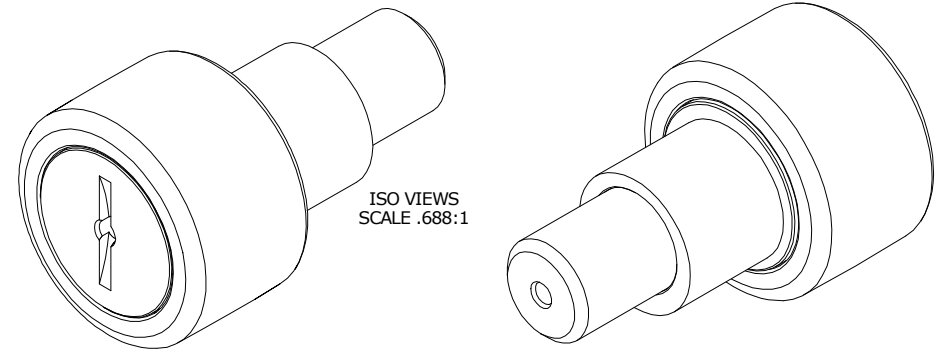

MATERIAL NOTES:

- OUTER RING - BEARING STEEL, HEAT TREATED
- STUD - BEARING STEEL, ZONE HARDENED
- NEEDLE ROLLER(S) - BEARING STEEL, HEAT TREATED
- WASHER - BEARING STEEL, HEAT TREATED
- ECCENTRIC SLEEVE - STEEL

CUSTOMER PART# _____
 XX = ± .01
 XXX = ± .005
 XXXX = ± .0005
 ANGLES = ± 1'
 INCH [METRIC]
 FRACTION = ± 1/32

CARTER MANUFACTURING IS NOT RESPONSIBLE FOR TYPOGRAPHICAL ERRORS

CARTER MANUFACTURING CO., INC.
 GRAND HAVEN, MICHIGAN 49417

ENGINEERING CHANGE ORDER NOTE

REVISION		PART NAME: ASSEMBLY			PRODUCT TYPE: CNB	
B	AUTHOR BY HG	DRAWN BY JAF	CHK'D BY MD	SALES KR	MATERIAL NOTED	
REVISION BY JLB	DATE 7/31/2018	DATE 7/12/2006	DATE 8/1/2018	DATE 8/1/2018	SHEET 1 OF 2	