

LOAD RATINGS	
RATING	Lbs
RADIAL BASIC DYNAMIC	4,840
MAXIMUM STATIC CAPACITY	5,640

NOTES:  
 1. BEARING IS PACKED WITH NLGI GRADE 2, LITHIUM BASED GREASE  
 2. ALL EXPOSED SURFACES HAVE BLACK OXIDE

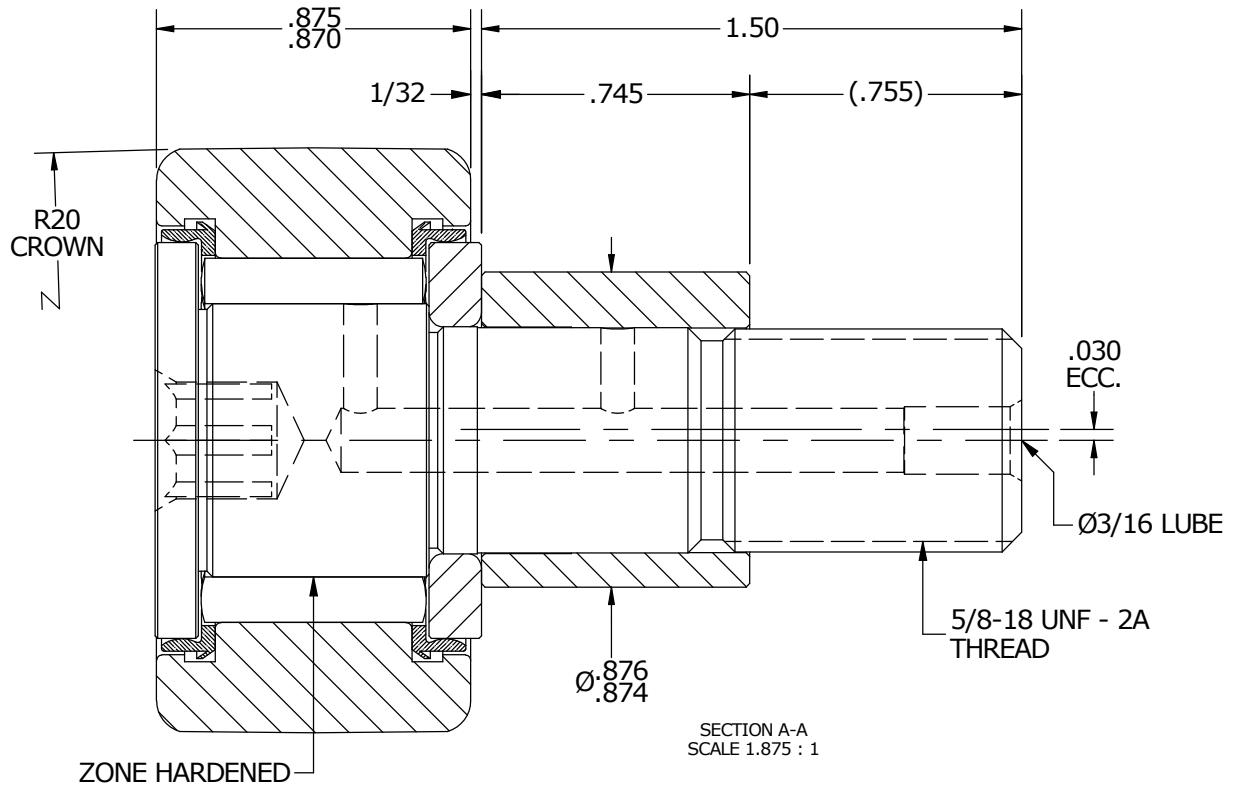
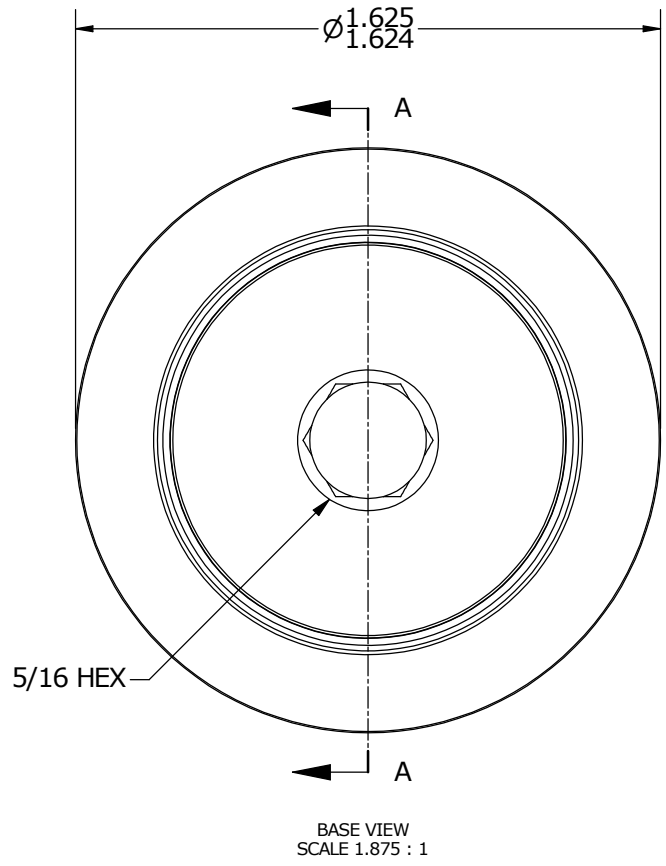
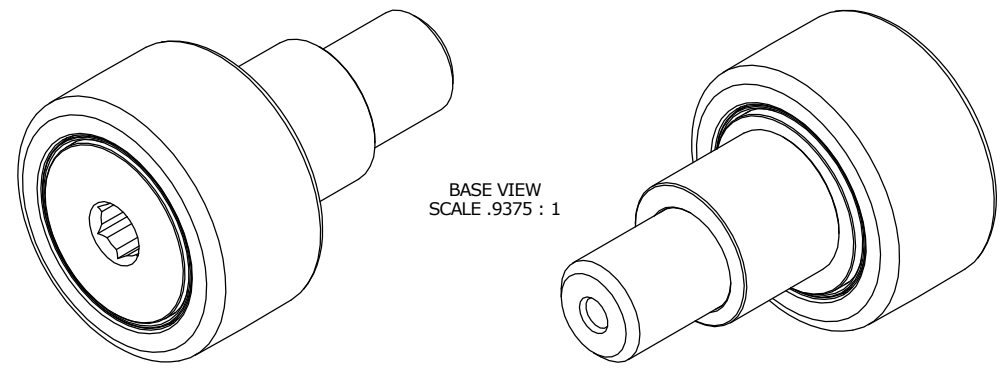

MATERIAL NOTES:

OUTER RACE - BEARING STEEL, HEAT TREATED  
 STUD - BEARING STEEL, ZONE HARDENED  
 NEEDLE ROLLERS - BEARING STEEL, HEAT TREATED  
 WASHER - COLD ROLLED STEEL, HEAT TREATED  
 ECCENTRIC SLEEVE - COLD ROLLED STEEL  
 SEALS - SYNTHETIC

CUSTOMER PART#	XX = ± .01 XXX = ± .005 XXXX = ± .0005 ANGLES = ± 1' INCH [METRIC] FRACTION = ± 1/32
<i>ENGINEERING CHANGE ORDER NOTE</i>	

CARTER MANUFACTURING IS NOT RESPONSIBLE FOR TYPOGRAPHICAL ERRORS		<b>CARTER MANUFACTURING CO., INC.</b> GRAND HAVEN, MICHIGAN 49417			
<i>REVISION</i>		PART NAME: ASSEMBLY			
<b>C</b>	AUTHOR BY DB	DRAWN BY EMD	CHK'D BY SGW	SALES KR	MATERIAL NOTED
REVISION BY MD	DATE 11/11/2013	DATE 7/13/2006	DATE 11/11/2013	DATE 11/2/2010	SHEET 1 OF 2