

LOAD RATINGS	
RATING	Lbs
RADIAL BASIC DYNAMIC	2,225
MAXIMUM STATIC CAPACITY	3,060

NOTES:
 1. BEARING IS PACKED WITH LITHIUM BASED #2 WEIGHT GREASE
 2. ALL EXPOSED SURFACES HAVE BLACK OXIDE

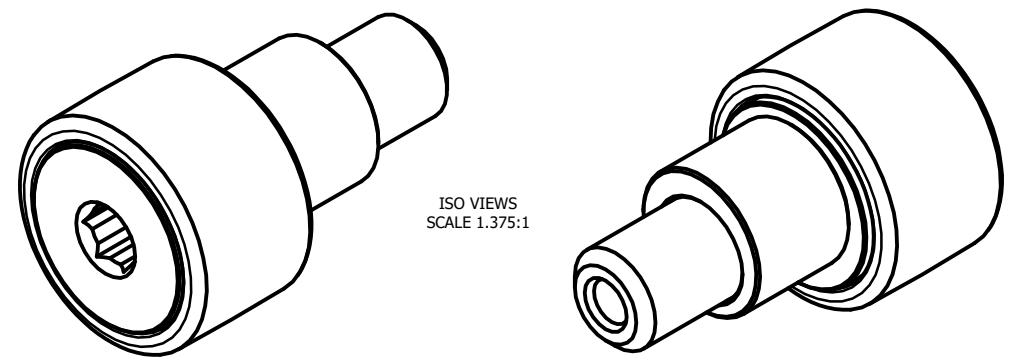

ISO VIEWS
 SCALE 1.375:1

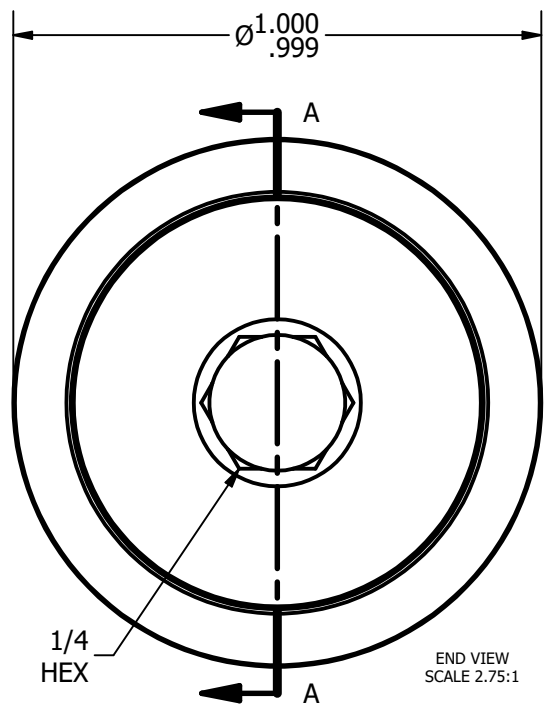

END VIEW
 SCALE 2.75:1

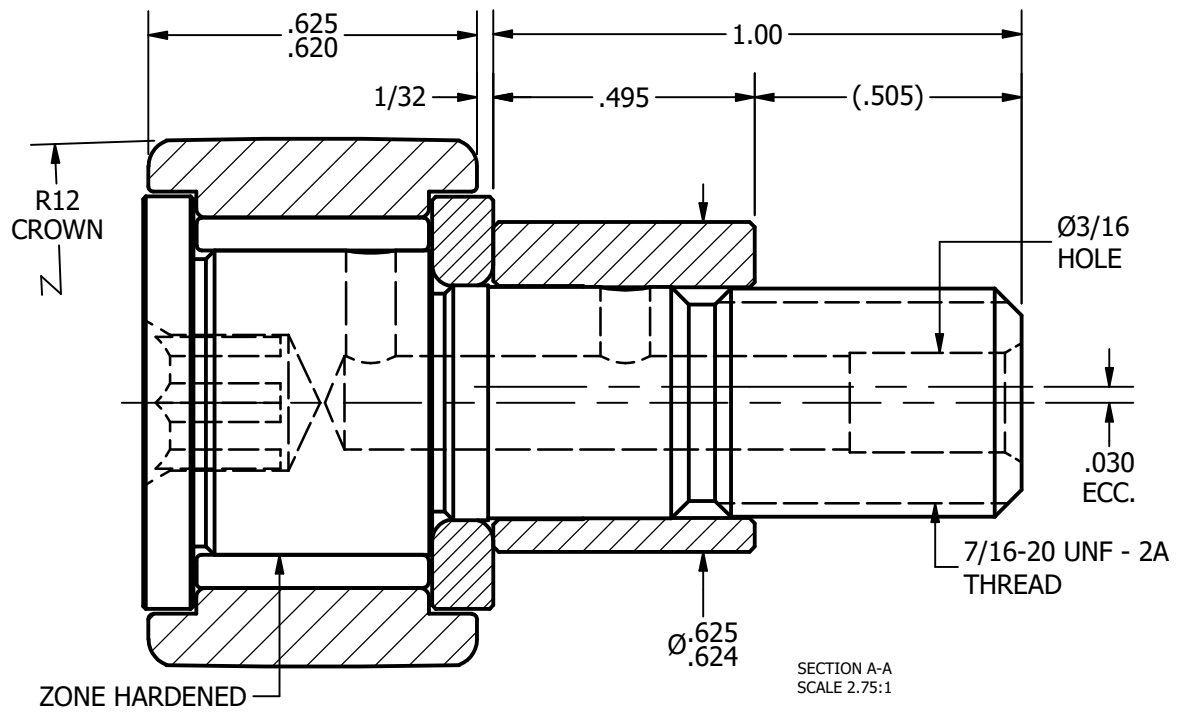

SECTION A-A
 SCALE 2.75:1

MATERIAL NOTES:
 OUTER RACE - BEARING STEEL, HEAT TREATED
 STUD - BEARING STEEL, ZONE HARDENED
 NEEDLE ROLLER - BEARING STEEL, HEAT TREATED
 WASHER - COLD ROLLED STEEL, HEAT TREATED
 ECCENTRIC SLEEVE - COLD ROLLED STEEL

CUSTOMER PART#
 .XX = ± .01
 .XXX = ± .005
 .XXXX = ± .0005
 ANGLES = ± 1'
 INCH [METRIC]
 FRACTION = ± 1/32

CHANGE NOTE:

CARTER MANUFACTURING IS NOT RESPONSIBLE FOR TYPOGRAPHICAL ERRORS

CARTER MANUFACTURING CO., INC.
 GRAND HAVEN, MICHIGAN 49417

REVISION		PART NAME: ASSEMBLY			SHEET 1 OF 2	
REV. BY	DATE	AUTHOR. BY	DRAWN BY	CHK'D BY	SALES	MATERIAL
B		DB	EMD	MD	KR	NOTED
SGW	4/24/2013		6/26/2006	4/24/2013	4/8/2013	CCNBE-32-B