

LOAD RATINGS		
RATING	Lbs	Newtons
RADIAL BASIC DYNAMIC	1,660	7,384
MAXIMUM STATIC CAPACITY	2,065	9,185

MS NO. \_\_\_\_\_ NSN NO. \_\_\_\_\_ DRAWING NO. CCNBE-28-S

RECOMMENDED MOUNTING HOLE Ø		
Limit	Inch	mm
MIN	.502	12.7508
MAX	.504	12.8016

- NOTES:
- BEARING IS PACKED WITH NLGI GRADE 2, LITHIUM BASED GREASE (UNLESS OTHERWISE SPECIFIED)
  - ALL EXPOSED STEEL SURFACES HAVE BLACK OXIDE
  - LIMITING SPEED:
    - A. GREASE = 5,400 RPM

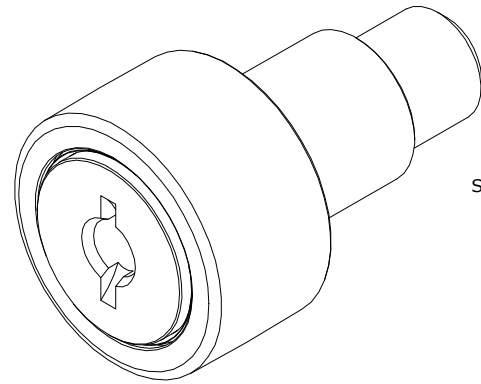

ISO VIEW  
SCALE 1.750:1

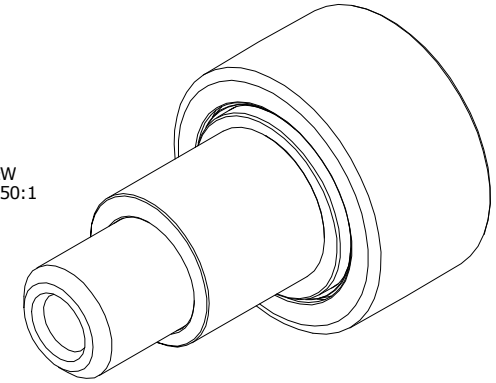

MAXIMUM CLAMPING TORQUE		
Thread Type	Inch Lbs	Nm
DRY	95	11
LUBRICATED	47.5	5.5

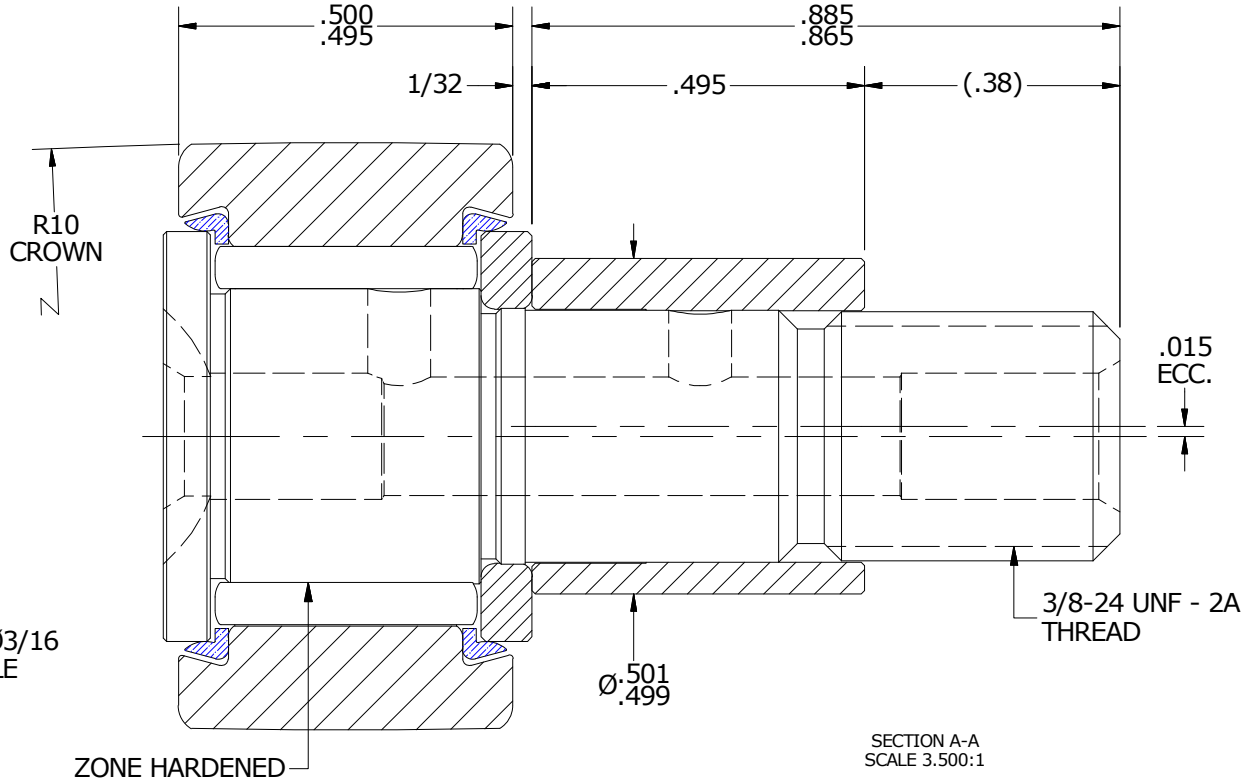
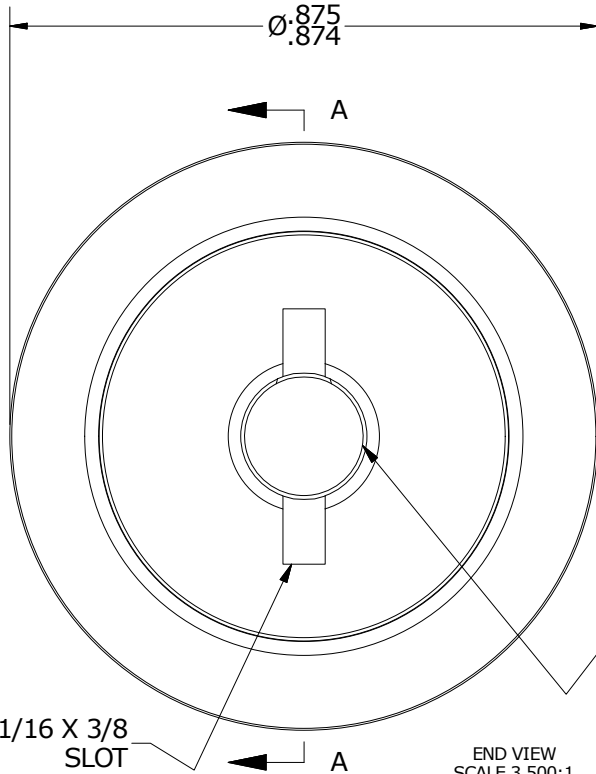

MATERIAL NOTES:

OUTER RING - BEARING STEEL, HEAT TREATED  
 STUD - BEARING STEEL, ZONE HARDENED  
 NEEDLE ROLLER(S) - BEARING STEEL, HEAT TREATED  
 WASHER - BEARING STEEL, HEAT TREATED  
 ECCENTRIC SLEEVE - COLD ROLLED STEEL  
 SEAL(S) - SYNTHETIC

CUSTOMER PART# \_\_\_\_\_  
 XX = ± .01  
 XXX = ± .005  
 XXXX = ± .0005  
 ANGLES = ± 1'  
 INCH [METRIC]  
 FRACTION = ± 1/32

CARTER MANUFACTURING IS NOT RESPONSIBLE FOR TYPOGRAPHICAL ERRORS

**CARTER MANUFACTURING CO., INC.**  
 GRAND HAVEN, MICHIGAN 49417

ENGINEERING CHANGE ORDER NOTE

REVISION		PART NAME: ASSEMBLY			
<b>B</b>	AUTHOR BY HG	DRAWN BY EMD	CHK'D BY MD	SALES KR	MATERIAL NOTED
REVISION BY SGW	DATE 5/1/2017	DATE 6/22/2006	DATE 4/28/2017	DATE 5/5/2017	SHEET 1 OF 2