

LOAD RATINGS		
RATING	Lbs	Newtons
RADIAL BASIC DYNAMIC	1,660	7,384
MAXIMUM STATIC CAPACITY	2,065	9,185

MS NO. _____ NSN NO. _____ DRAWING NO. CCNBE-28-B

RECOMMENDED MOUNTING HOLE Ø		
Limit	Inch	mm
MIN	.502	12.7508
MAX	.504	12.8016

- NOTES:
- BEARING IS PACKED WITH NLGI GRADE 2, LITHIUM BASED GREASE (UNLESS OTHERWISE SPECIFIED)
 - ALL EXPOSED STEEL SURFACES HAVE BLACK OXIDE
 - LIMITING SPEED:
 - GREASE = 5,400 RPM

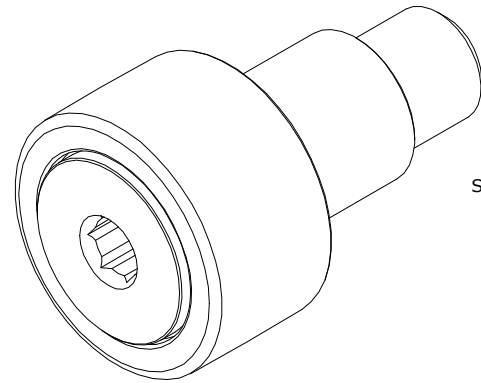

ISO VIEW
SCALE 1.750:1

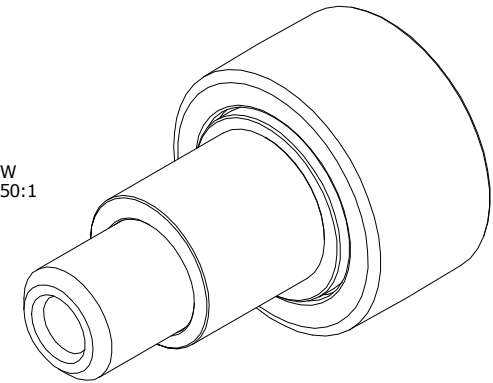

MAXIMUM CLAMPING TORQUE		
Thread Type	Inch Lbs	Nm
DRY	95	11
LUBRICATED	47.5	5.5

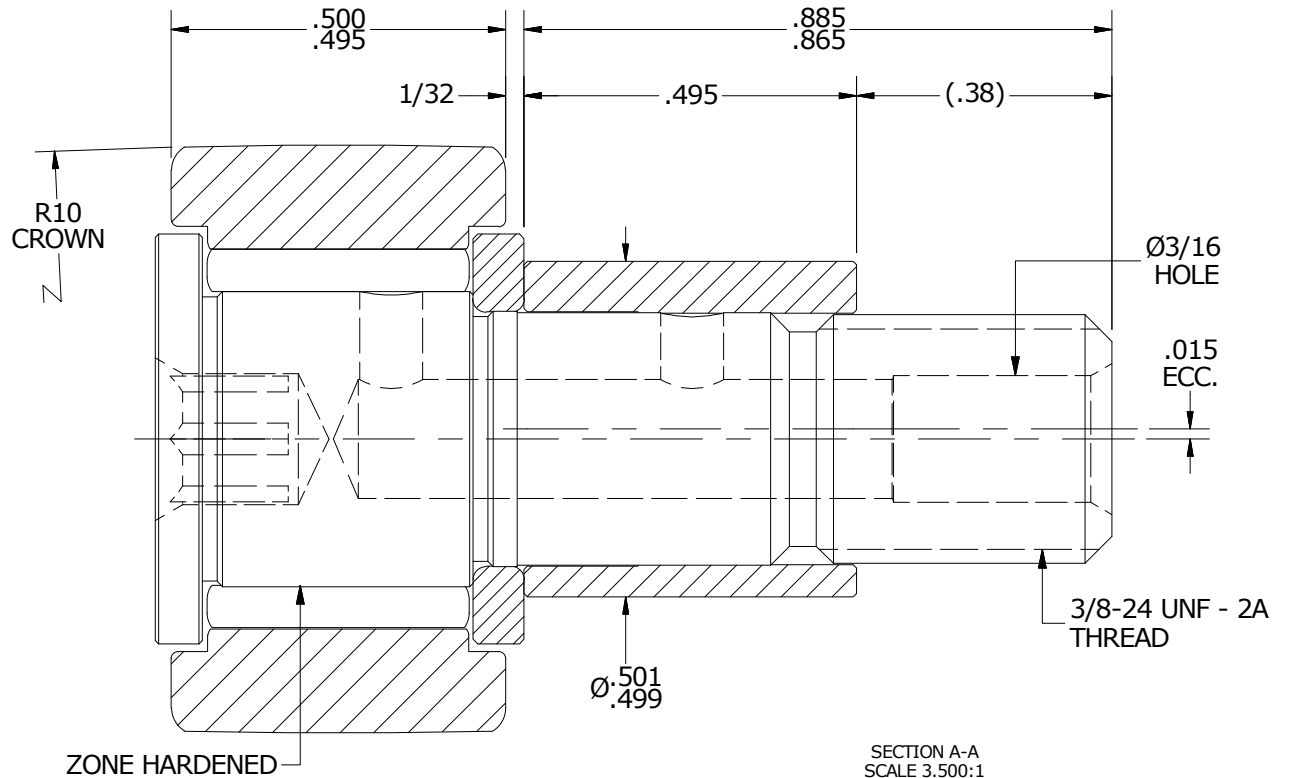
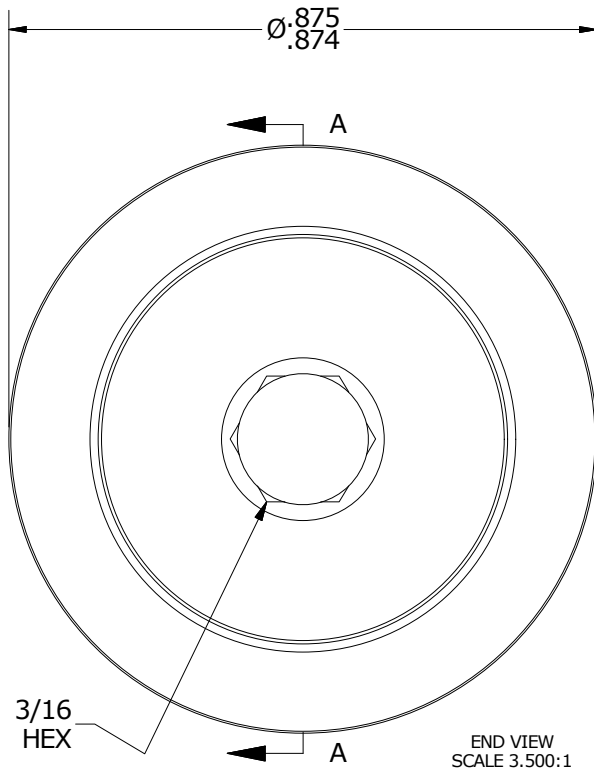

MATERIAL NOTES:

OUTER RING - BEARING STEEL, HEAT TREATED
 STUD - BEARING STEEL, ZONE HARDENED
 NEEDLE ROLLER(S) - BEARING STEEL, HEAT TREATED
 WASHER - BEARING STEEL, HEAT TREATED
 ECCENTRIC SLEEVE - COLD ROLLED STEEL

CUSTOMER PART#
 XX = ± .01
 XXX = ± .005
 XXXX = ± .0005
 ANGLES = ± 1'
 INCH [METRIC]
 FRACTION = ± 1/32

CARTER MANUFACTURING IS NOT RESPONSIBLE FOR TYPOGRAPHICAL ERRORS

CARTER MANUFACTURING CO., INC.
 GRAND HAVEN, MICHIGAN 49417

ENGINEERING CHANGE ORDER NOTE

REVISION		PART NAME: ASSEMBLY			
B	AUTHOR BY HG	DRAWN BY EMD	CHK'D BY MD	SALES KR	MATERIAL NOTED
REVISION BY SGW	DATE 5/1/2017	DATE 6/22/2006	DATE 4/28/2017	DATE 5/5/2017	SHEET 1 OF 2