

LOAD RATINGS	
RATING	Lbs
RADIAL BASIC DYNAMIC	955
MAXIMUM STATIC CAPACITY	1,215

NOTES:  
 1. BEARING IS PACKED WITH NLGI GRADE 2, LITHIUM BASED GREASE  
 2. ALL EXPOSED SURFACES HAVE BLACK OXIDE

MS NO. \_\_\_\_\_ NSN NO. \_\_\_\_\_ DRAWING NO. CCNBE-20-S

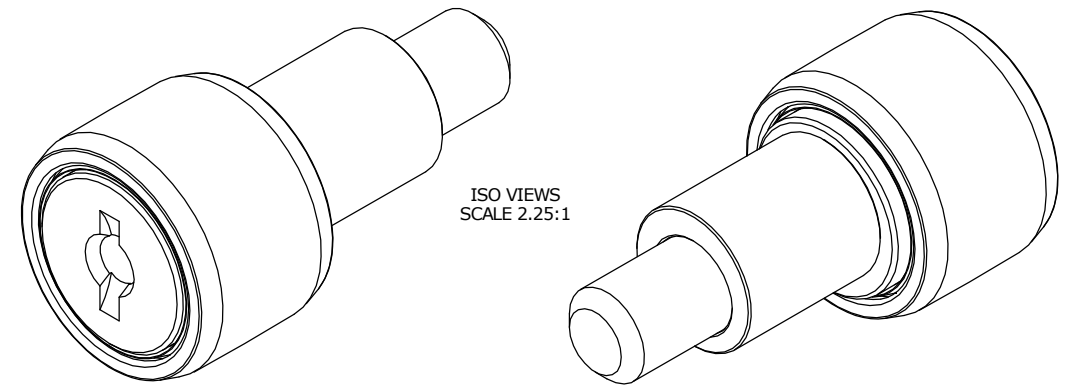

ISO VIEWS  
SCALE 2.25:1

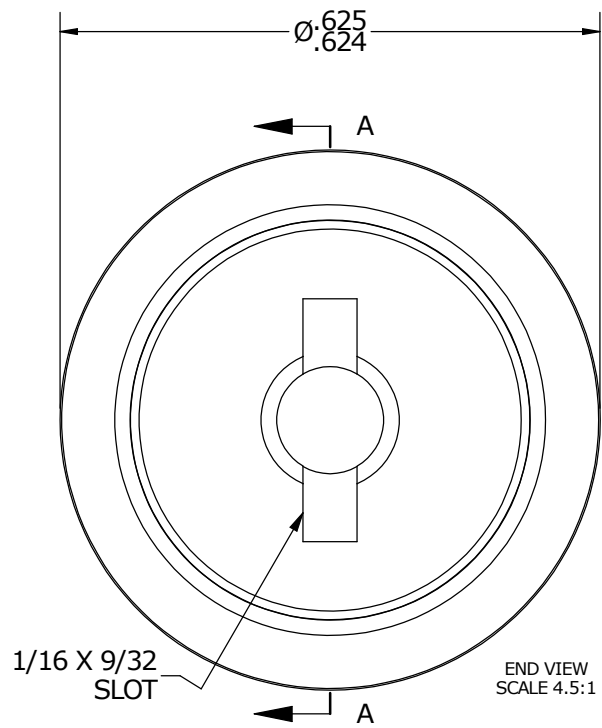

END VIEW  
SCALE 4.5:1

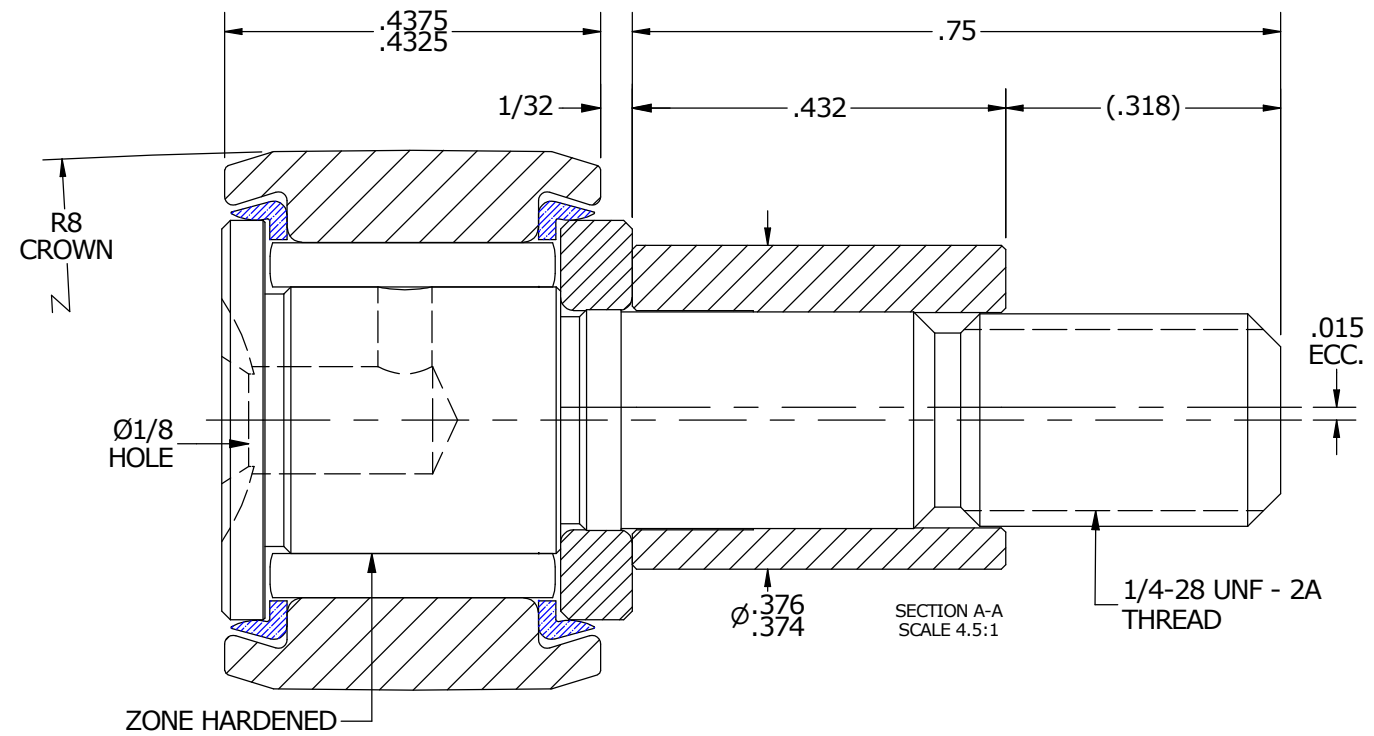

SECTION A-A  
SCALE 4.5:1

MATERIAL NOTES:  
 OUTER RACE - BEARING STEEL, HEAT TREATED  
 STUD - BEARING STEEL, ZONE HARDENED  
 NEEDLE ROLLER - BEARING STEEL, HEAT TREATED  
 WASHER - COLD ROLLED STEEL, HEAT TREATED  
 SEAL - SYNTHETIC  
 ECCENTRIC SLEEVE - COLD ROLLED STEEL

CUSTOMER PART# \_\_\_\_\_  
 XX = ± .01  
 XXX = ± .005  
 XXXX = ± .0005  
 ANGLES = ± 1'  
 INCH [METRIC]  
 FRACTION = ± 1/32

CARTER MANUFACTURING IS NOT RESPONSIBLE FOR TYPOGRAPHICAL ERRORS

**CARTER MANUFACTURING CO., INC.**  
 GRAND HAVEN, MICHIGAN 49417

ENGINEERING CHANGE ORDER NOTE

<b>B</b>	AUTHOR BY HG
REVISION BY SGW	DATE 5/12/2014

REVISION		PART NAME: ASSEMBLY			
REVISION BY	DATE	DRAWN BY	CHK'D BY	SALES	MATERIAL
B	5/12/2014	EMD	MD	KR	NOTED
SGW	5/12/2014	6/20/2006	5/12/2014	5/12/2014	SHEET 1 OF 2