

LOAD RATINGS	
RATING	Lbs
RADIAL BASIC DYNAMIC [C]	620
MAXIMUM STATIC CAPACITY [Co]	720

NOTES:
 1. BEARING IS PACKED WITH LITHIUM BASED #2 WEIGHT GREASE
 2. ALL EXPOSED SURFACES HAVE BLACK OXIDE

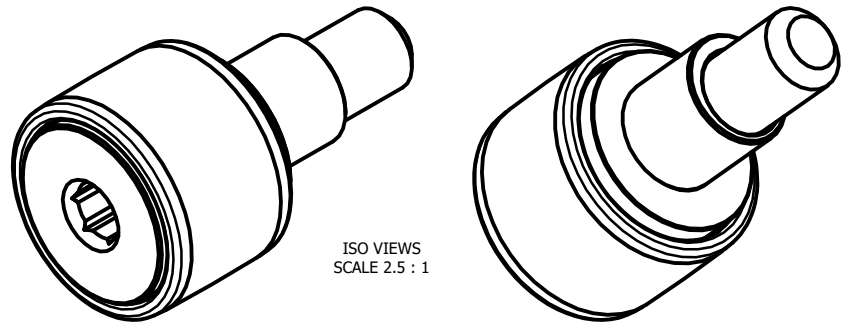

ISO VIEWS
 SCALE 2.5 : 1

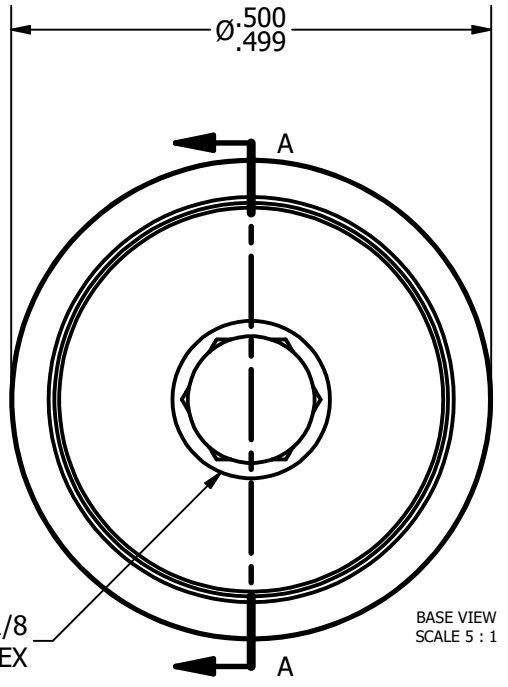

BASE VIEW
 SCALE 5 : 1

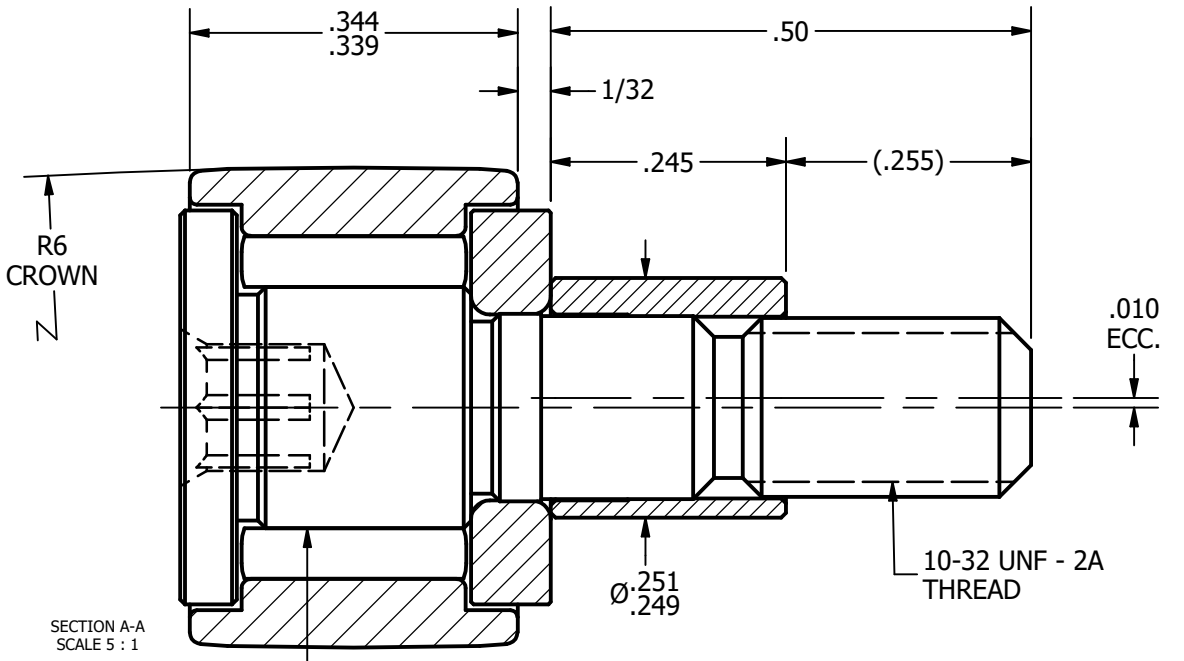

SECTION A-A
 SCALE 5 : 1

ZONE HARDENED

MATERIAL NOTES:
 OUTER RACE - BEARING STEEL, HEAT TREATED
 STUD - BEARING STEEL, ZONE HARDENED
 NEEDLE ROLLER - BEARING STEEL, HEAT TREATED
 WASHER - COLD ROLLED STEEL, HEAT TREATED
 ECCENTRIC SLEEVE - COLD ROLLED STEEL

CUSTOMER PART#	.XX = ± .01 .XXX = ± .005 .XXXX = ± .0005 ANGLES = ± 1' INCH [METRIC] FRACTION = ± 1/32
CHANGE NOTE:	

CARTER MANUFACTURING IS NOT RESPONSIBLE FOR TYPOGRAPHICAL ERRORS

REVISION	
C	
REV. BY	DATE
SGW	6/23/2011

CARTER MANUFACTURING CO., INC.
 GRAND HAVEN, MICHIGAN 49417

PART NAME: ASSEMBLY		SHEET 1 OF 2			
AUTHOR. BY	DRAWN BY	CHK'D BY	SALES	MATERIAL	
DB	EMD	MD	KR	NOTED	
REV. BY	DATE	DATE	DATE	DATE	DRAWING NO.
SGW	6/23/2011	6/13/2006	6/23/2011	6/23/2011	CCNBE-16-NB