

LOAD RATINGS	
RATING	Lbs
RADIAL BASIC DYNAMIC [C]	680
MAXIMUM STATIC CAPACITY [Co]	790

- NOTES:
 1. BEARING IS PACKED WITH LITHIUM BASED #2 WEIGHT GREASE
 2. ALL EXPOSED SURFACES HAVE BLACK OXIDE

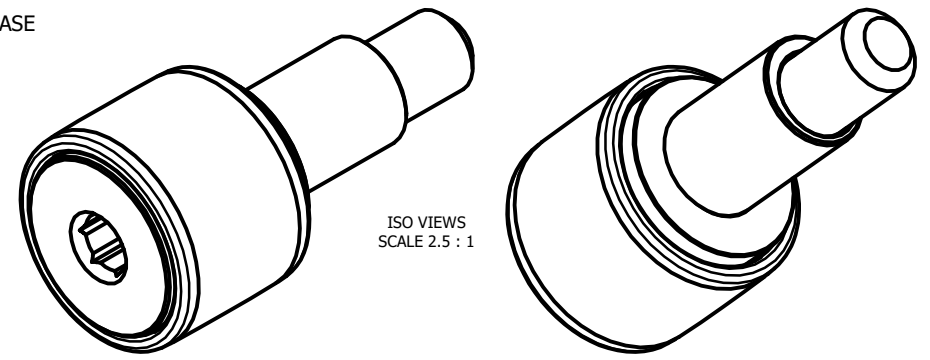

ISO VIEWS
 SCALE 2.5 : 1

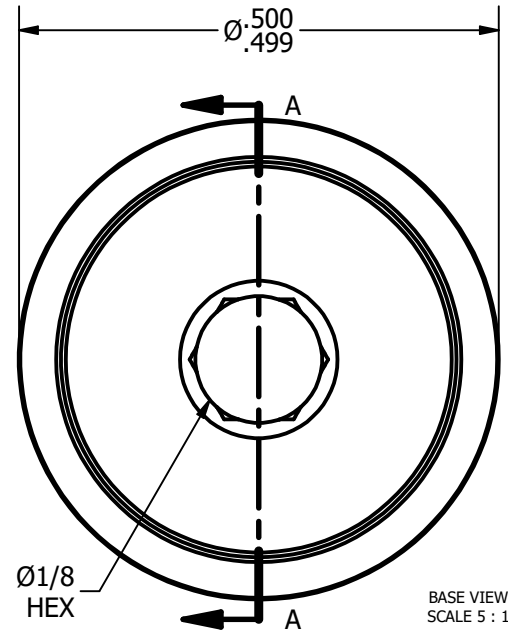

BASE VIEW
 SCALE 5 : 1

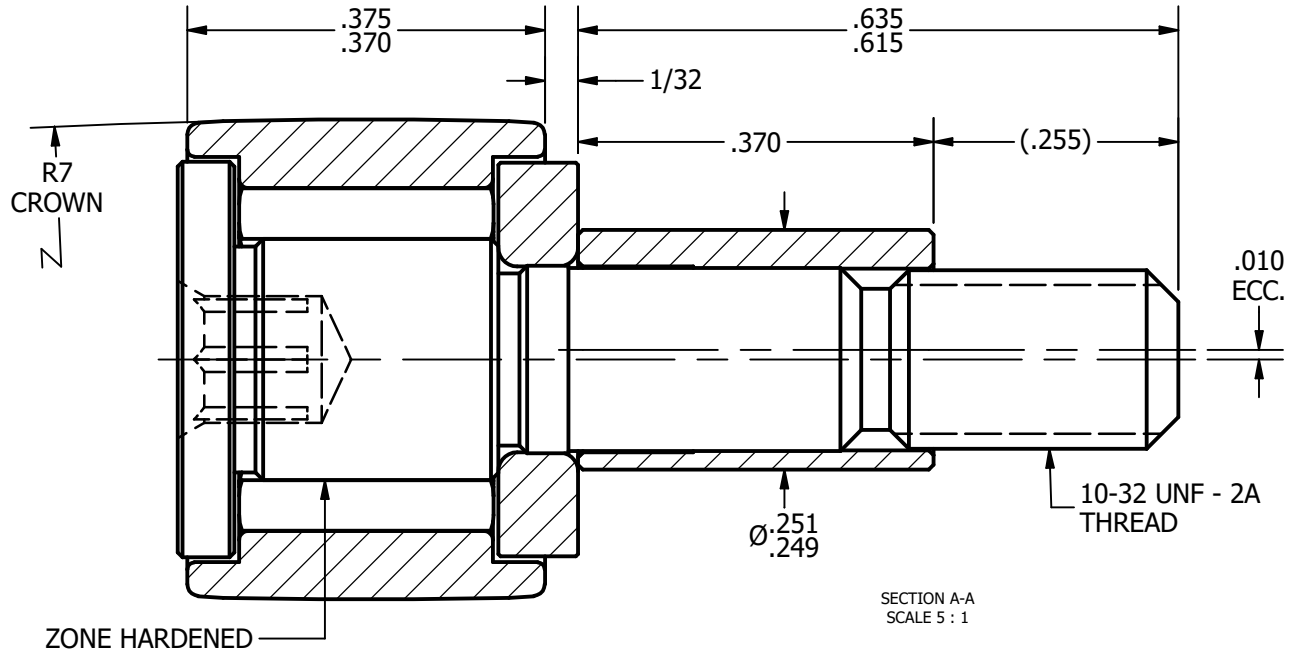

SECTION A-A
 SCALE 5 : 1

MATERIAL NOTES:
 OUTER RACE - BEARING STEEL, HEAT TREATED
 STUD - BEARING STEEL, ZONE HARDENED
 NEEDLE ROLLER - BEARING STEEL, HEAT TREATED
 WASHER - COLD ROLLED STEEL, HEAT TREATED
 ECCENTRIC SLEEVE - COLD ROLLED STEEL

CUSTOMER PART#	.XX = ± .01 .XXX = ± .005 .XXXX = ± .0005 ANGLES = ± 1' INCH [METRIC] FRACTION = ± 1/32
CHANGE NOTE:	

CARTER MANUFACTURING IS NOT RESPONSIBLE FOR TYPOGRAPHICAL ERRORS

REVISION	AUTHOR. BY	DRAWN BY	CHK'D BY	SALES	MATERIAL
C	DB	EMD	MD	KR	NOTED
REV. BY	DATE	DATE	DATE	DATE	DRAWING NO.
SGW	2/25/2011	6/13/2006	2/25/2011	3/8/2011	CCNBE-16-B

CARTER MANUFACTURING CO., INC.
 GRAND HAVEN, MICHIGAN 49417

PART NAME: ASSEMBLY SHEET 1 OF 2