

- NOTES:**
 1. BEARING IS PACKED WITH GREASE
 2. ALL EXPOSED SURFACES ARE BLACK OXIDED

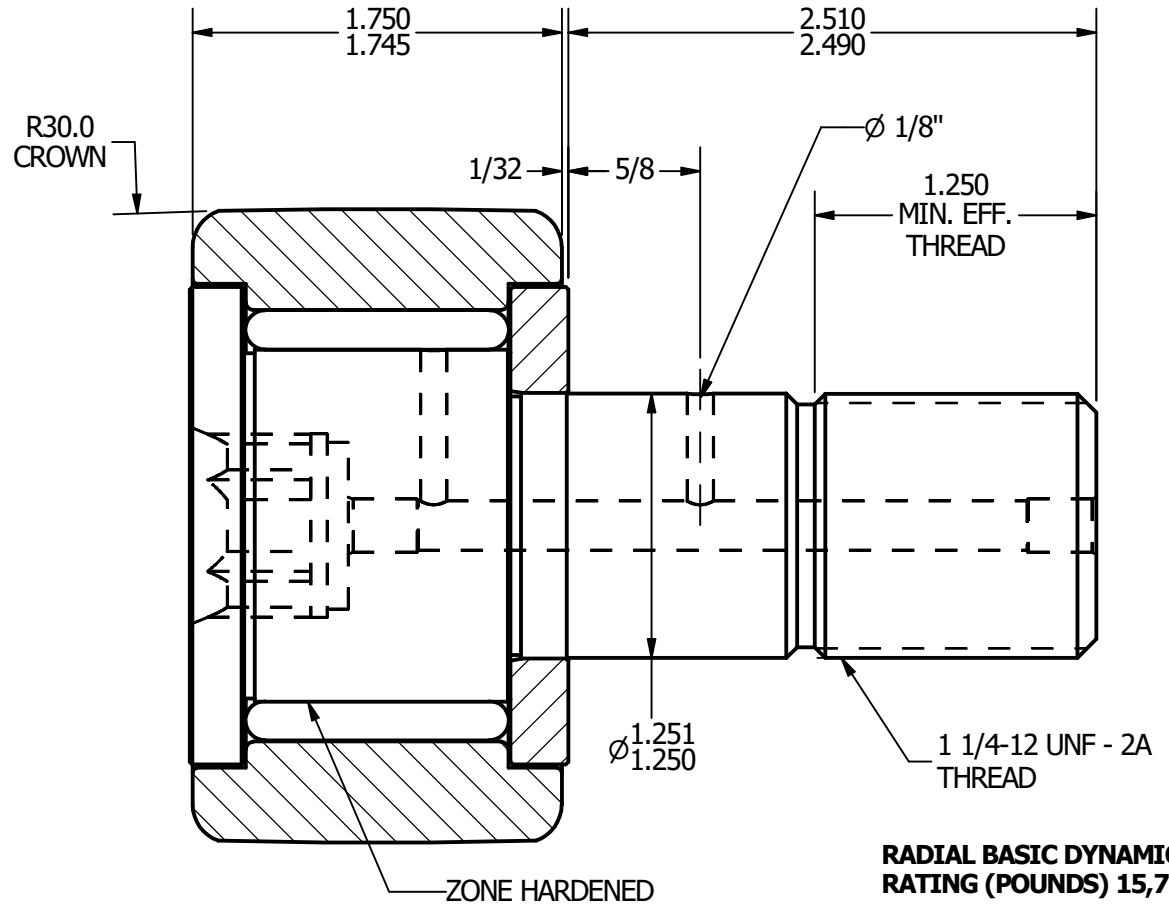
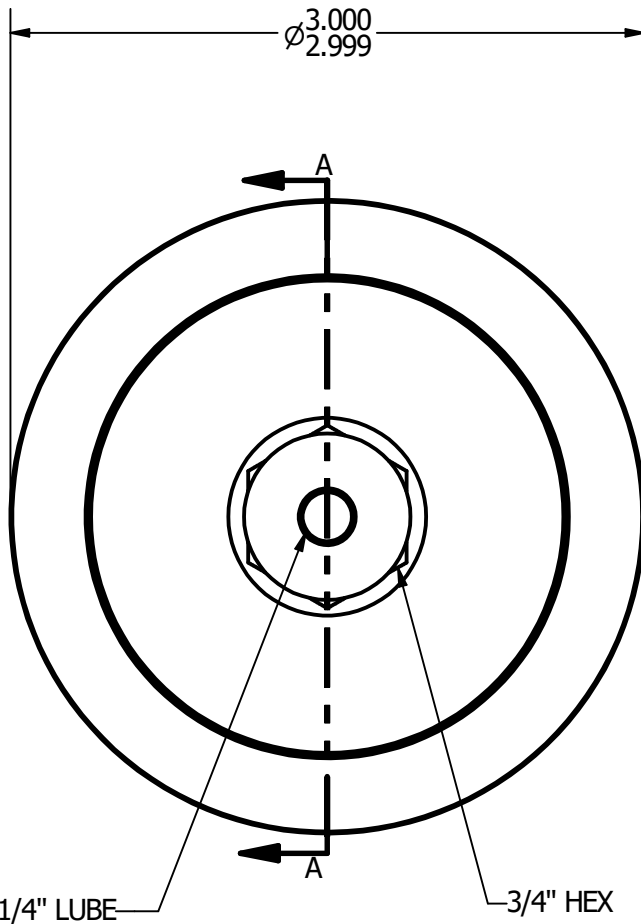
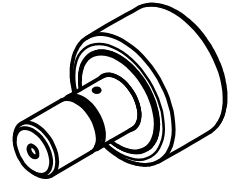

RADIAL BASIC DYNAMIC RATING (POUNDS) 15,720

MAXIMUM STATIC CAPACITY (POUNDS) 24,910

MATERIAL NOTES:
 OUTER - BEARING STEEL, HEAT TREATED
 STUD - BEARING STEEL, ZONE HARDENED
 ROLLER - BEARING STEEL, HEAT TREATED
 WASHER - COLD ROLLED STEEL, HEAT TREATED

CUSTOMER PART#
 .XX = ± .01
 .XXX = ± .005
 .XXXX = ± .0005
 ANGLES = ± 1'
 INCH [METRIC]

CARTER MANUFACTURING IS NOT RESPONSIBLE FOR TYPOGRAPHICAL ERRORS

CARTER MANUFACTURING CO., INC.
 GRAND HAVEN, MICHIGAN 49417

CHANGE NOTE:

REVISION		PART NAME: Assembly				SHEET 1 OF 2
A	AUTHOR. BY	DRAWN BY	CHK'D BY	SALES	MATERIAL	
	JGV	EMD	JGV	KPR	NOTED	
	REV. BY	DATE	DATE	DATE	DRAWING NO.	
EMD	7/7/2006	7/7/2006	7/7/2006	7/7/2006	CCNB-96-B	