

LOAD RATINGS		
RATING	lbf	Newtons
RADIAL BASIC DYNAMIC	8,090	35,986
MAXIMUM STATIC CAPACITY	10,570	47,018

MS NO. _____ NSN NO. _____ DRAWING NO. CCNB-72

RECOMMENDED MOUNTING HOLE Ø		
Limit	Inch	mm
MIN	.8750	22.2250
MAX	.8755	22.2377

- NOTES:
1. BEARING IS PACKED WITH NLGI GRADE 2, LITHIUM BASED GREASE (UNLESS OTHERWISE SPECIFIED)
 2. ALL EXPOSED SURFACES HAVE BLACK OXIDE
 3. LIMITING SPEED:
A. GREASE = 1,400 RPM

MAXIMUM CLAMPING TORQUE		
Thread Type	Inch Lbs	Nm
DRY	1500	169.5
LUBRICATED	750	84.7

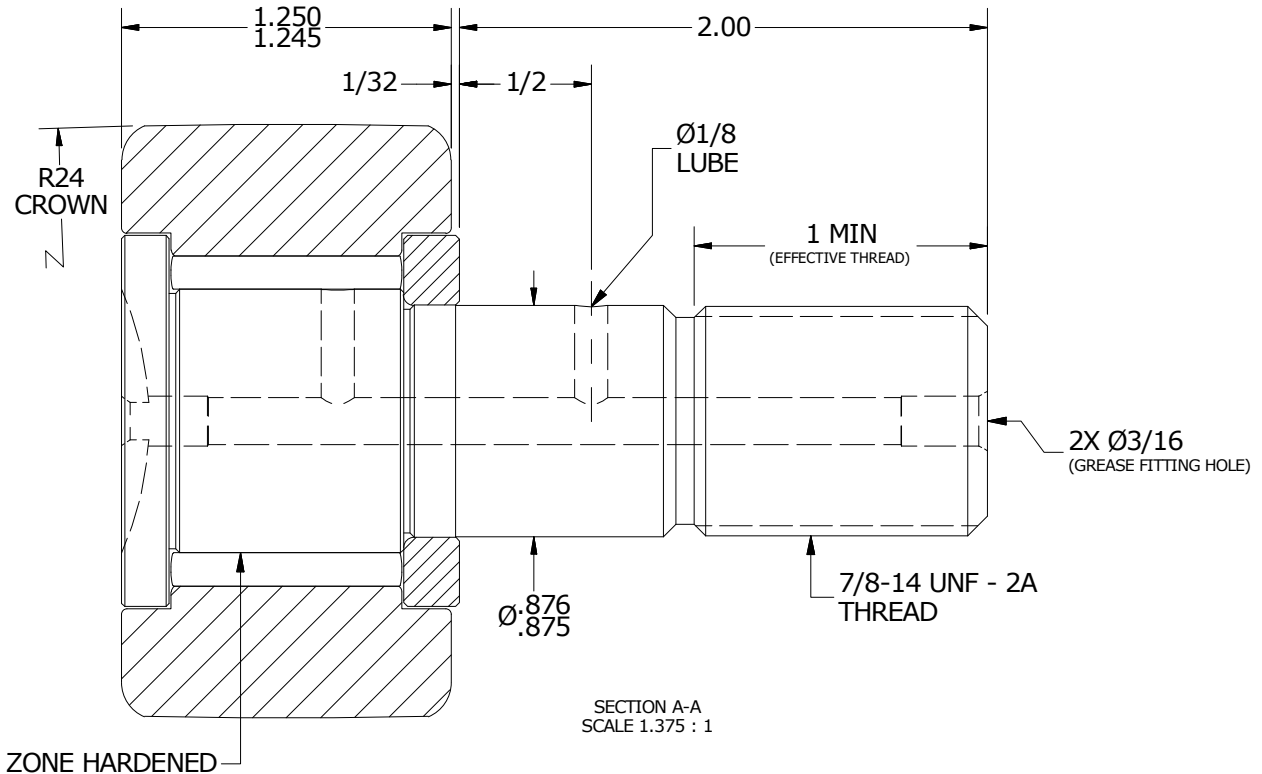
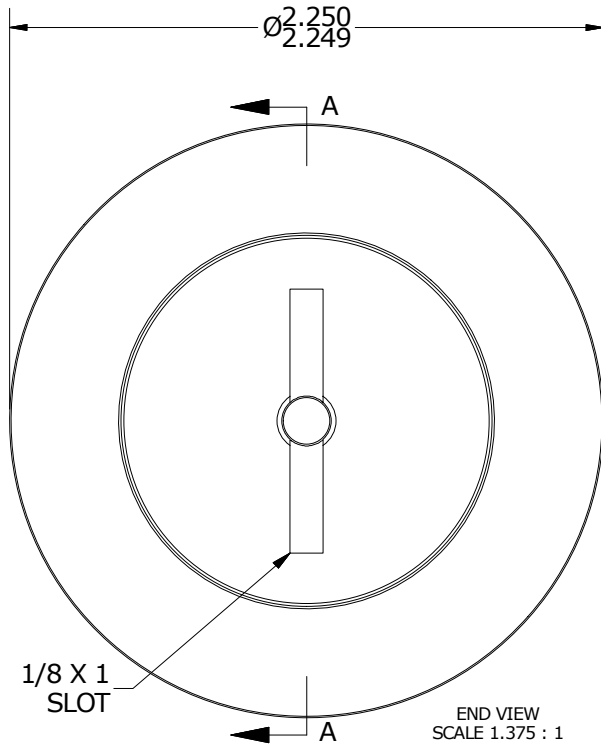
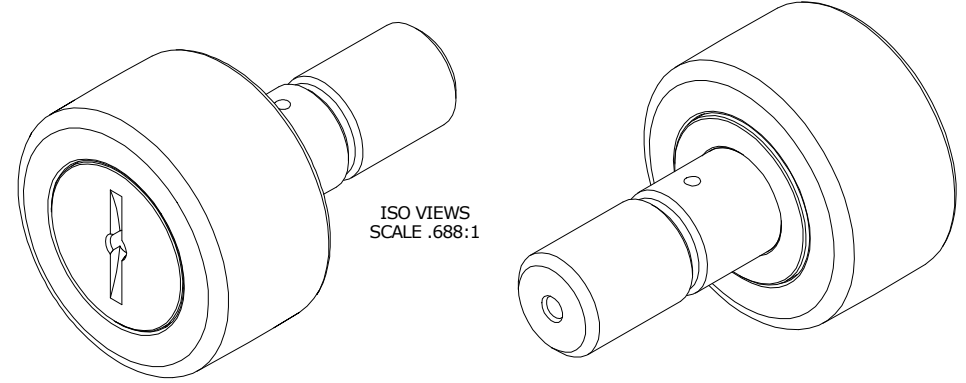

MATERIAL NOTES:

- OUTER RING - BEARING STEEL, HEAT TREATED
- STUD - BEARING STEEL, ZONE HARDENED
- NEEDLE ROLLER(S) - BEARING STEEL, HEAT TREATED
- WASHER - BEARING STEEL, HEAT TREATED

CUSTOMER PART#

XX = ± .01
 XXX = ± .005
 XXXX = ± .0005
 ANGLES = ± 1'
 INCH [METRIC]
 FRACTION = ± 1/32

CARTER MANUFACTURING IS NOT RESPONSIBLE FOR TYPOGRAPHICAL ERRORS

CARTER MANUFACTURING CO., INC.
 GRAND HAVEN, MICHIGAN 49417

ENGINEERING CHANGE ORDER NOTE

REVISION

PART NAME: ASSEMBLY

PRODUCT TYPE: CNB

B

AUTHOR BY
HG

DRAWN BY
JAF

CHK'D BY
MD

SALES
KR

MATERIAL
NOTED

REVISION BY
JLB

DATE
8/1/2018

DATE
7/12/2006

DATE
8/1/2018

DATE
8/2/2018

SHEET
1 OF 2