

LOAD RATINGS		
RATING	lbf	Newtons
RADIAL BASIC DYNAMIC	8,090	35,986
MAXIMUM STATIC CAPACITY	10,570	47,018

- NOTES:
- BEARING IS PACKED WITH NLGI GRADE 2, LITHIUM BASED GREASE (UNLESS OTHERWISE SPECIFIED)
  - ALL EXPOSED SURFACES HAVE BLACK OXIDE
  - LIMITING SPEED:  
A. GREASE = 1,400 RPM

RECOMMENDED MOUNTING HOLE Ø		
Limit	Inch	mm
MIN	.8750	22.2250
MAX	.8755	22.2377

MAXIMUM CLAMPING TORQUE		
Thread Type	Inch Lbs	Nm
DRY	1500	169.5
LUBRICATED	750	84.7

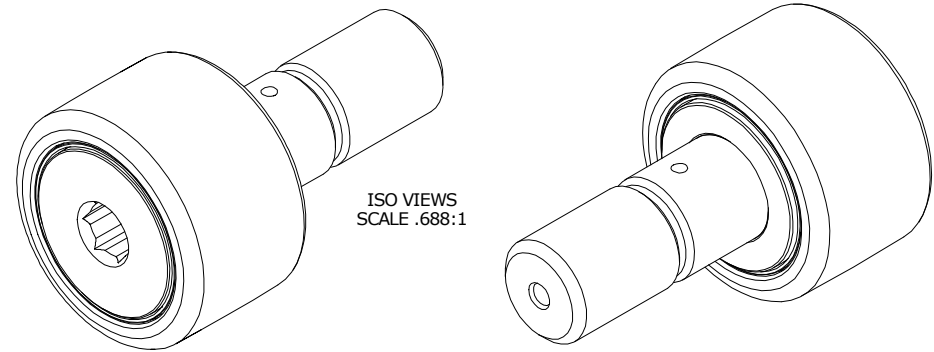

ISO VIEWS  
SCALE .688:1

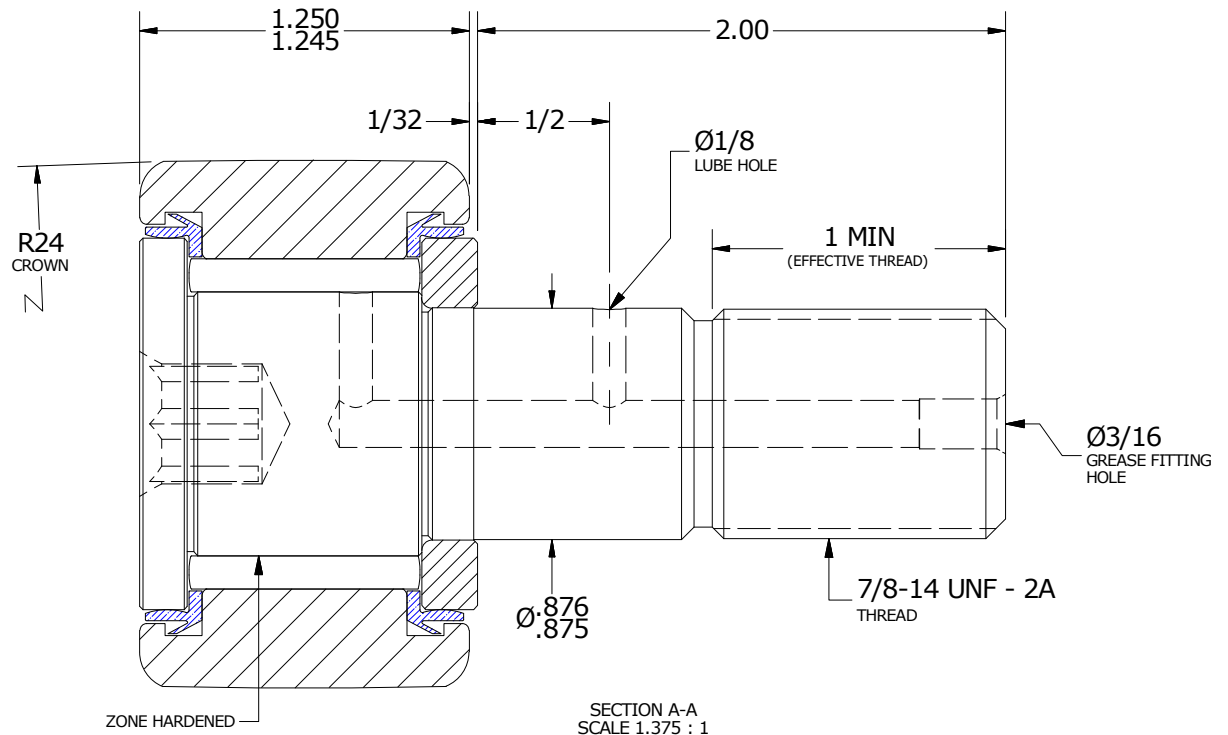
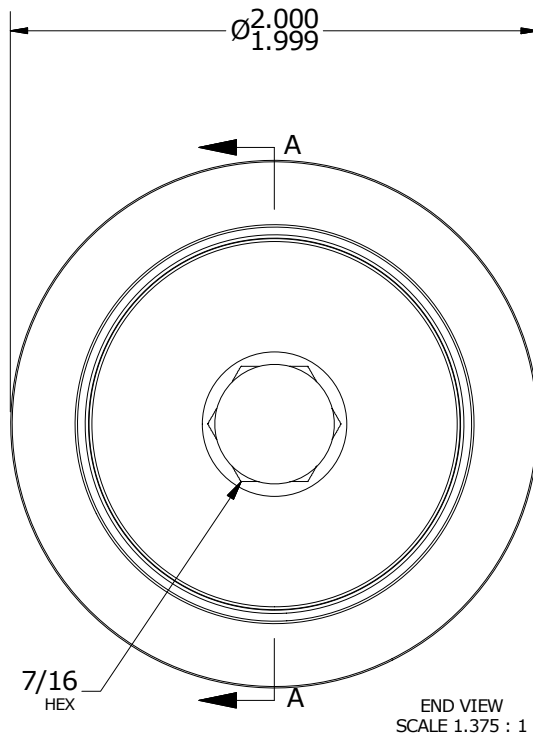

MATERIAL NOTES:

- OUTER RING - BEARING STEEL, HEAT TREATED
- STUD - BEARING STEEL, ZONE HARDENED
- NEEDLE ROLLER(S) - BEARING STEEL, HEAT TREATED
- WASHER - BEARING STEEL, HEAT TREATED
- SEAL(S) - SYNTHETIC

CUSTOMER PART#

XX = ± .01  
XXX = ± .005  
XXXX = ± .0005  
ANGLES = ± 1'  
INCH [METRIC]  
FRACTION = ± 1/32

CARTER MANUFACTURING IS NOT RESPONSIBLE FOR TYPOGRAPHICAL ERRORS

**CARTER MANUFACTURING CO., INC.**

GRAND HAVEN, MICHIGAN 49417

ENGINEERING CHANGE ORDER NOTE

REVISION

PART NAME: ASSEMBLY

PRODUCT TYPE: CNB

C

AUTHOR BY  
HG

DRAWN BY  
JAF

CHK'D BY  
MD

SALES  
KR

MATERIAL  
NOTED

REVISION BY  
SGW

DATE  
7/19/2018

DATE  
7/12/2006

DATE  
7/19/2018

DATE  
7/19/2018

SHEET  
1 OF 2