

| LOAD RATINGS | |
|-------------------------|-------|
| RATING | Lbs |
| RADIAL BASIC DYNAMIC | 4,840 |
| MAXIMUM STATIC CAPACITY | 5,640 |

NOTES:
 1. BEARING IS PACKED WITH LITHIUM BASED #2 WEIGHT GREASE
 2. ALL EXPOSED SURFACES HAVE BLACK OXIDE

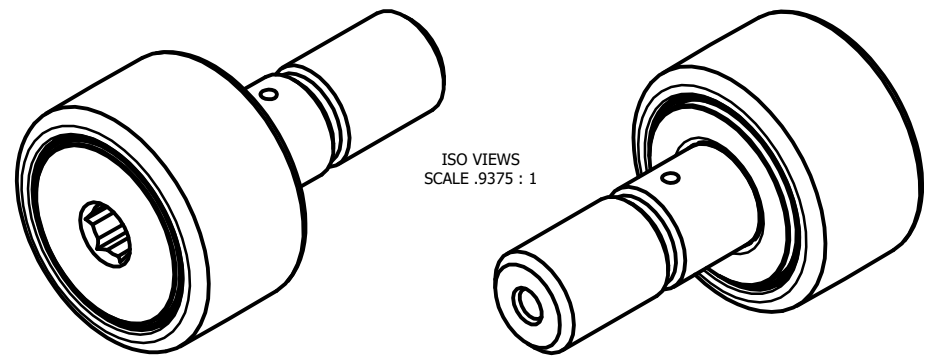

ISO VIEWS
 SCALE .9375 : 1

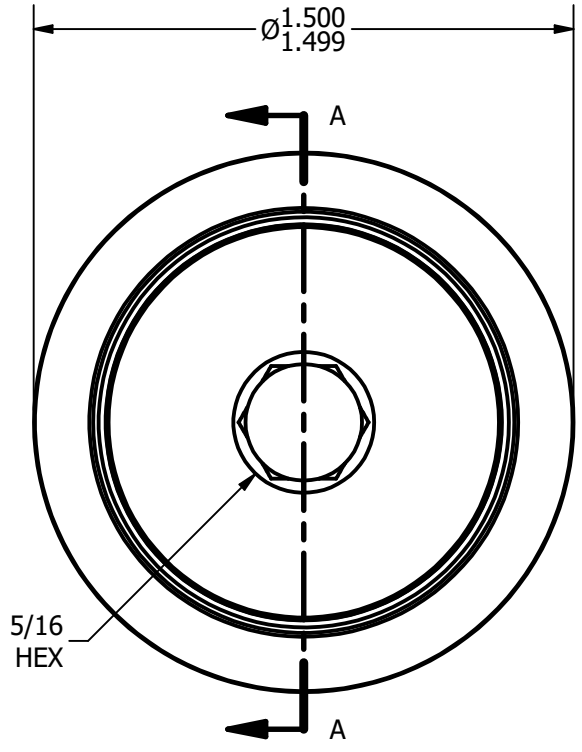

BASE VIEW
 SCALE 1.875 : 1

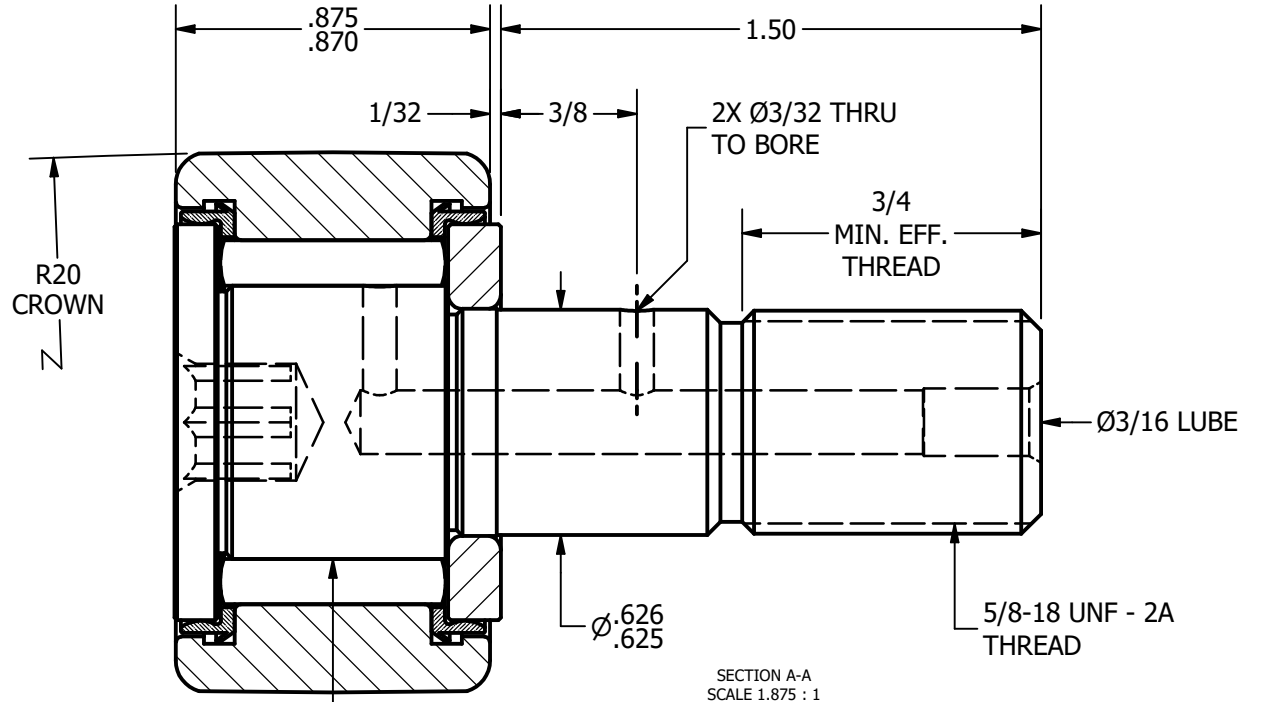

SECTION A-A
 SCALE 1.875 : 1

MATERIAL NOTES:
 OUTER RACE - BEARING STEEL, HEAT TREATED
 STUD - BEARING STEEL, ZONE HARDENED
 NEEDLE ROLLERS - BEARING STEEL, HEAT TREATED
 WASHER - COLD ROLLED STEEL, HEAT TREATED
 SEALS - SYNTHETIC

| | |
|----------------|--|
| CUSTOMER PART# | .XX = ± .01 .XXX = ± .005 .XXXX = ± .0005 ANGLES = ± 1° INCH [METRIC] FRACTION = ± 1/32 |
| CHANGE NOTE: | |

| | |
|--|---------------|
| CARTER MANUFACTURING IS NOT RESPONSIBLE FOR TYPOGRAPHICAL ERRORS | |
| REVISION | |
| C | AUTHOR. BY DB |
| REV. BY MD | DATE 3/6/2013 |

| | | | | | |
|---------------------------------------|----------|------------------------|--------------|----------|----------|
| CARTER MANUFACTURING CO., INC. | | | | | |
| GRAND HAVEN, MICHIGAN 49417 | | | | | |
| PART NAME: ASSEMBLY | | | SHEET 1 OF 2 | | |
| SALES | MATERIAL | DATE | DATE | DATE | DATE |
| KR | NOTED | 10/24/2010 | 7/13/2006 | 3/6/2013 | 3/6/2013 |
| | | DRAWING NO. CCNB-48-SB | | | |