

LOAD RATINGS		
RATING	lbf	Newtons
RADIAL BASIC DYNAMIC	3,930	17,481
MAXIMUM STATIC CAPACITY	4,250	18,904

MS NO.	NSN NO.	DRAWING NO.
--------	---------	-------------

RECOMMENDED MOUNTING HOLE Ø		
Limit	Inch	mm
MIN	.5000	12.7072
MAX	.5005	12.7085

MAXIMUM CLAMPING TORQUE		
Thread Type	Inch Lbs	Nm
DRY	350	40
LUBRICATED	175	20

- NOTES:
- BEARING IS PACKED WITH NLGI GRADE 2, LITHIUM BASED GREASE (UNLESS OTHERWISE SPECIFIED)
 - ALL EXPOSED STEEL SURFACES HAVE BLACK OXIDE
 - LIMITING SPEED:
 - A. GREASE = 3,100 RPM

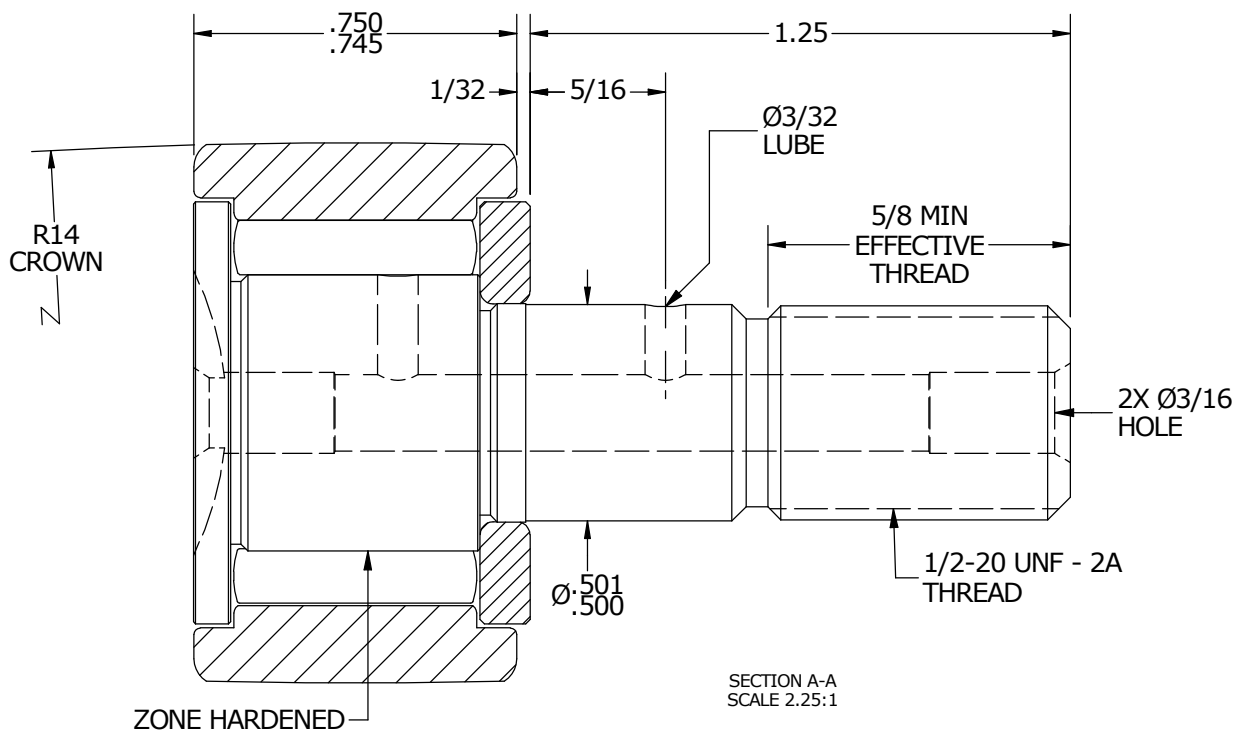
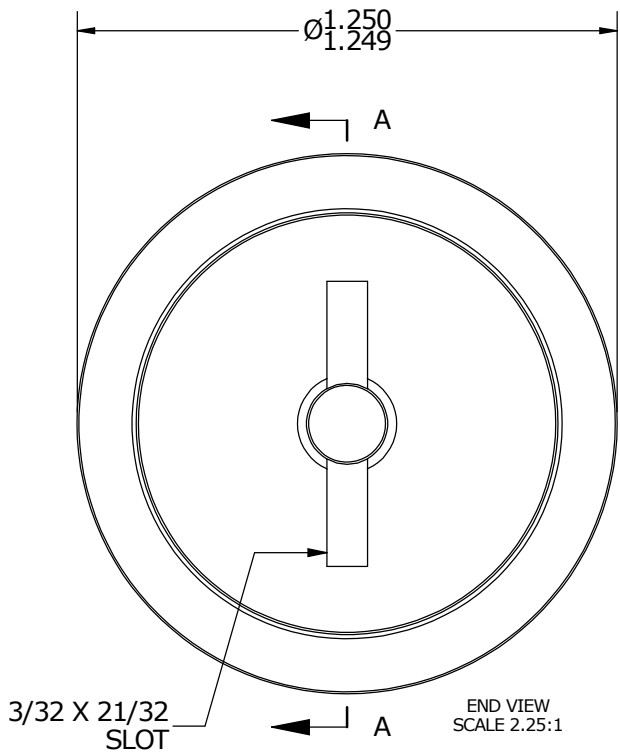
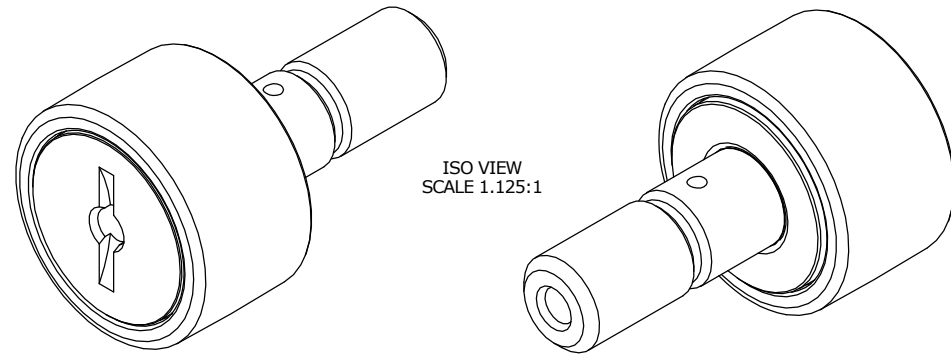

MATERIAL NOTES:

- OUTER RING - BEARING STEEL, HEAT TREATED
- STUD - BEARING STEEL, ZONE HARDENED
- NEEDLE ROLLER - BEARING STEEL, HEAT TREATED
- WASHER - BEARING STEEL, HEAT TREATED*

*(MAY BE CONSTRUCTED FROM COLD ROLLED STEEL DEPENDING ON MATERIAL AVAILABILITY)

CUSTOMER PART#

XX = ± .01
 XXX = ± .005
 XXXX = ± .0005
 ANGLES = ± 1'
 INCH [METRIC]
 FRACTION = ± 1/32

CARTER MANUFACTURING IS NOT RESPONSIBLE FOR TYPOGRAPHICAL ERRORS

CARTER MANUFACTURING CO., INC.

GRAND HAVEN, MICHIGAN 49417

ENGINEERING CHANGE ORDER NOTE

REVISION

PART NAME: ASSEMBLY

REVISION	AUTHOR BY	DRAWN BY	CHK'D BY	SALES	MATERIAL
B	HG	JAF	MD	KR	NOTED
REVISION BY	DATE	DATE	DATE	DATE	SHEET
SGW	5/26/2016	6/29/2006	5/25/2016	6/1/2016	1 OF 2