

LOAD RATINGS		
RATING	Lbs	Newtons
RADIAL BASIC DYNAMIC	1,660	7,384
MAXIMUM STATIC CAPACITY	2,065	9,185

MS NO. _____ NSN NO. _____ DRAWING NO. CCNB-28-S

RECOMMENDED MOUNTING HOLE Ø		
Limit	Inch	mm
MIN	.3750	9.5250
MAX	.3755	9.5377

- NOTES:
1. BEARING IS PACKED WITH NLGI GRADE 2, LITHIUM BASED GREASE (UNLESS OTHERWISE SPECIFIED)
 2. ALL EXPOSED SURFACES HAVE BLACK OXIDE
 3. CUSTOM LASER ETCHING IS AVAILABLE UPON REQUEST
 4. LIMITING SPEED:
 - A. GREASE = 5,400 RPM

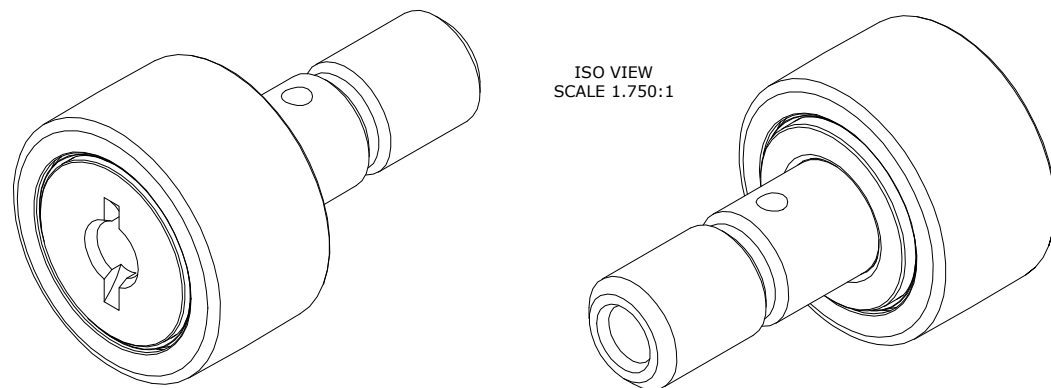

MAXIMUM CLAMPING TORQUE**		
Thread Type	Inch Lbs	Nm
LUBRICATED	47.5	5.5

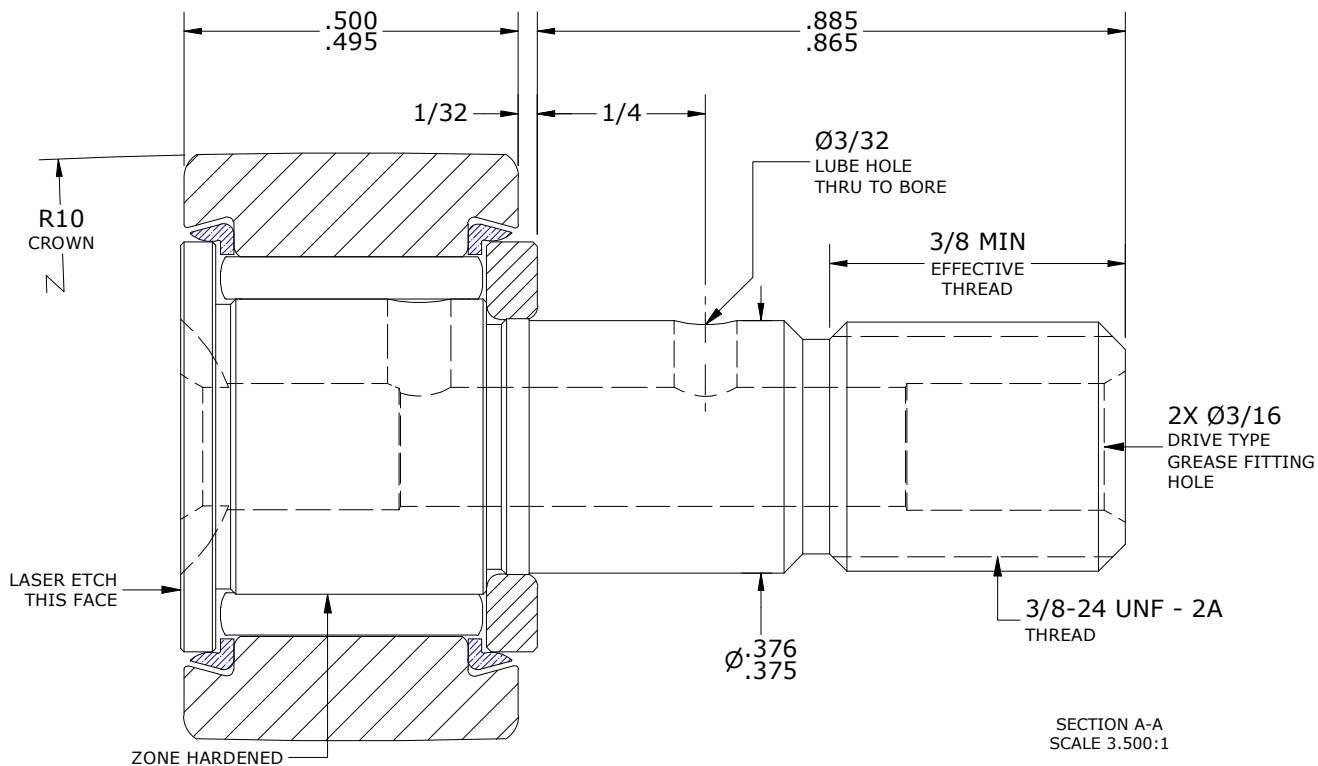
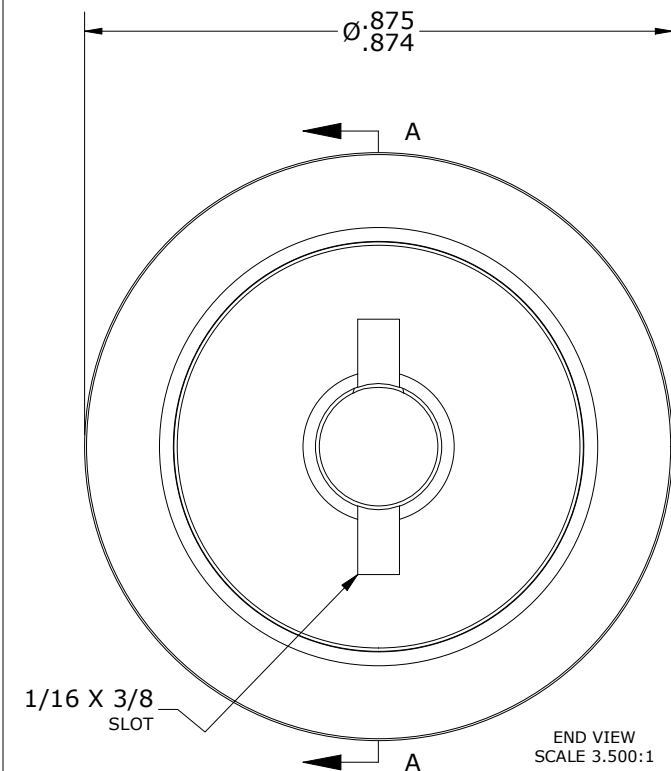

**TORQUE SPECIFICATION IS BASED ON LUBRICATED THREADS, IF USING DRY THREADS DOUBLE TORQUE VALUE

MATERIAL NOTES:

- OUTER RING - BEARING STEEL, HEAT TREATED
- STUD - BEARING STEEL, ZONE HARDENED
- NEEDLE ROLLER(S) - BEARING STEEL, HEAT TREATED
- WASHER - BEARING STEEL, HEAT TREATED
- SEAL(S) - SYNTHETIC

CUSTOMER PART#	XX = ± .01 XXX = ± .005 XXXX = ± .0005 ANGLES = ± 1' INCH [METRIC] FRACTION = ± 1/32
ENGINEERING CHANGE ORDER NOTE	

CARTER MANUFACTURING IS NOT RESPONSIBLE FOR TYPOGRAPHICAL ERRORS

CARTER MANUFACTURING CO., INC.
GRAND HAVEN, MICHIGAN 49417

REVISION		PART NAME: ASSEMBLY			PRODUCT TYPE: CCNB	
C	AUTHOR BY HG	DRAWN BY EMD	CHK'D BY MD	SALES KR	MATERIAL NOTED	
REVISION BY SGW	DATE 6/23/2020	DATE 6/6/2000	DATE 6/22/2020	DATE 5/5/2017	SHEET 1 OF 2	