

LOAD RATINGS		
RATING	Lbs	Newtons
RADIAL BASIC DYNAMIC	1,660	7,384
MAXIMUM STATIC CAPACITY	2,065	9,185

MS NO.	NSN NO.	DRAWING NO.	CCNB-24
--------	---------	-------------	---------

RECOMMENDED MOUNTING HOLE Ø		
Limit	Inch	mm
MIN	.3750	9.5250
MAX	.3755	9.5377

- NOTES:
- BEARING IS PACKED WITH NLGI GRADE 2, LITHIUM BASED GREASE (UNLESS OTHERWISE SPECIFIED)
 - ALL EXPOSED STEEL SURFACES HAVE BLACK OXIDE
 - LIMITING SPEED:
A. GREASE = 6,400 RPM

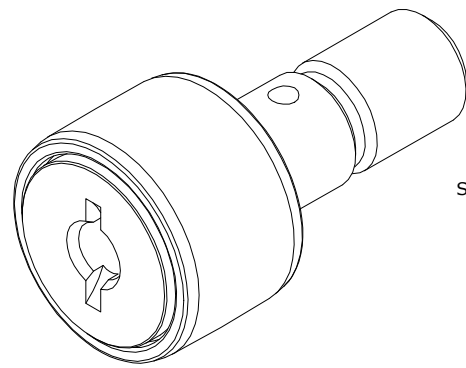

ISO VIEW
SCALE 1.750:1

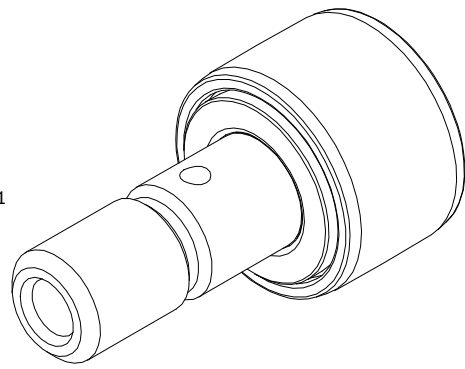

MAXIMUM CLAMPING TORQUE		
Thread Type	Inch Lbs	Nm
DRY	95	11
LUBRICATED	47.5	5.5

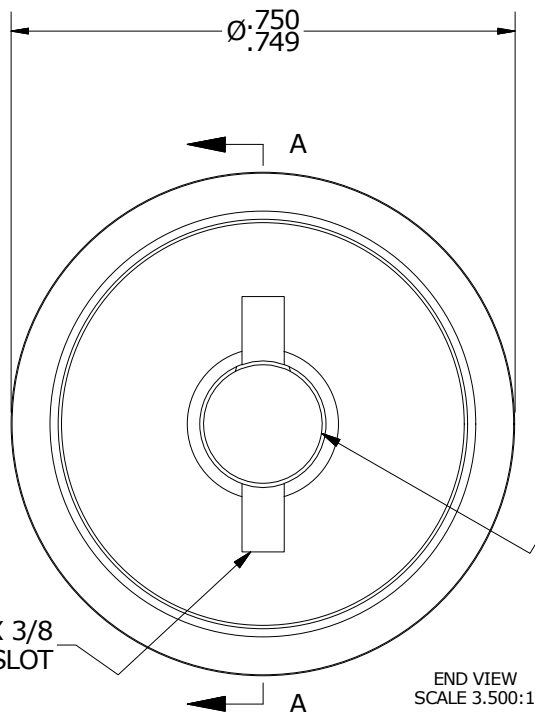

END VIEW
SCALE 3.500:1

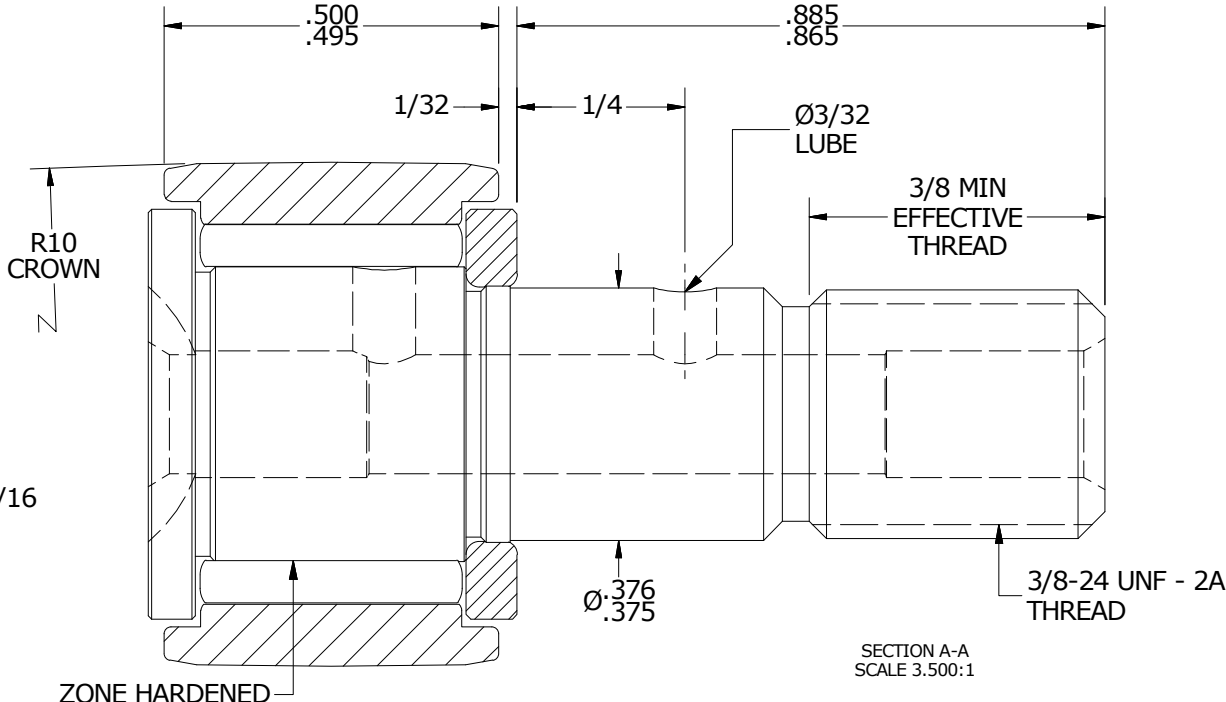

SECTION A-A
SCALE 3.500:1

MATERIAL NOTES:

OUTER RING - BEARING STEEL, HEAT TREATED
 STUD - BEARING STEEL, ZONE HARDENED
 NEEDLE ROLLER(S) - BEARING STEEL, HEAT TREATED
 WASHER - BEARING STEEL, HEAT TREATED

CUSTOMER PART#	XX = ± .01 XXX = ± .005 XXXX = ± .0005 ANGLES = ± 1' INCH [METRIC] FRACTION = ± 1/32
ENGINEERING CHANGE ORDER NOTE	

CARTER MANUFACTURING IS NOT RESPONSIBLE FOR TYPOGRAPHICAL ERRORS	
REVISION	
B	AUTHOR BY HG
REVISION BY SGW	DATE 4/28/2017

CARTER MANUFACTURING CO., INC. GRAND HAVEN, MICHIGAN 49417					
PART NAME: ASSEMBLY					
DRAWN BY EMD	CHK'D BY MD	SALES KR	MATERIAL NOTED		
DATE 6/22/2006	DATE 4/28/2017	DATE 5/5/2017	SHEET 1 OF 2		