

LOAD RATINGS	
RATING	Lbs
RADIAL BASIC DYNAMIC [C]	620
MAXIMUM STATIC CAPACITY [Co]	720

- NOTES:  
 1. BEARING IS PACKED WITH LITHIUM BASED #2 WEIGHT GREASE  
 2. ALL EXPOSED SURFACES HAVE BLACK OXIDE

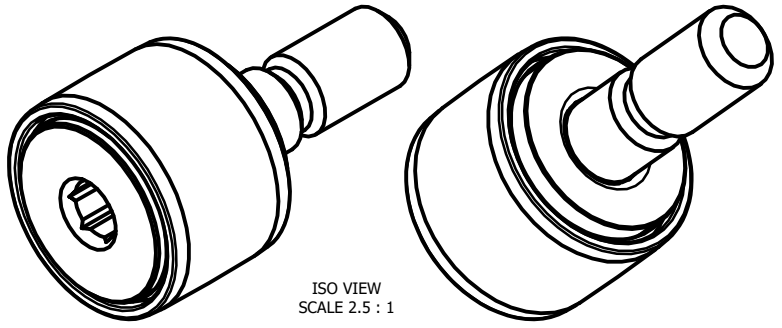

ISO VIEW  
 SCALE 2.5 : 1

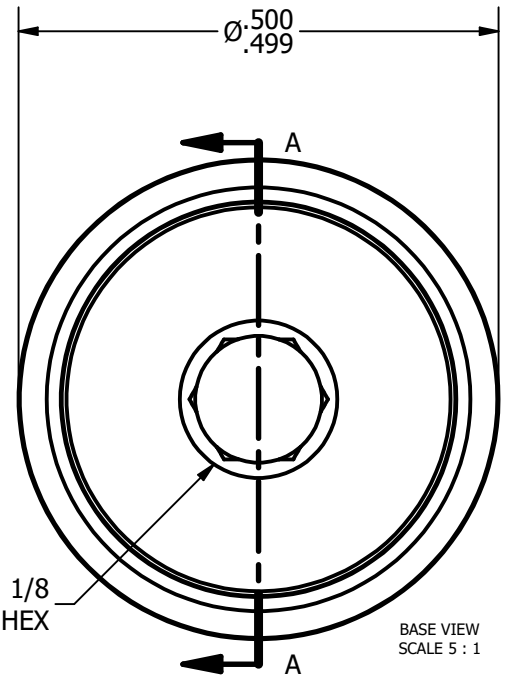

BASE VIEW  
 SCALE 5 : 1

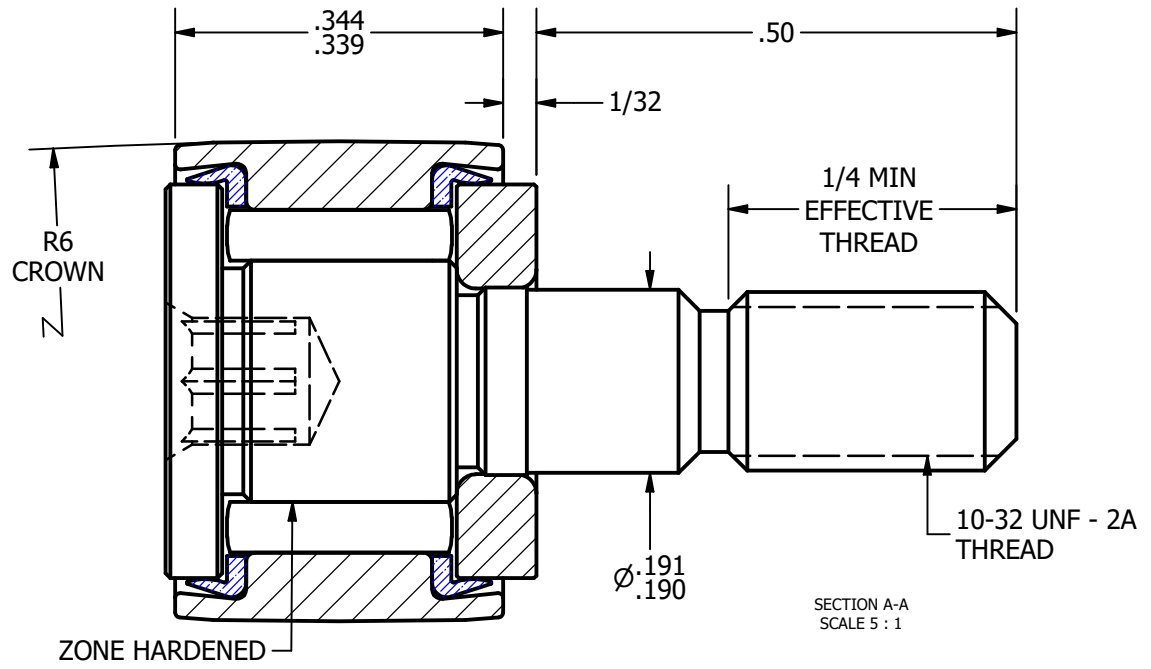

SECTION A-A  
 SCALE 5 : 1

**MATERIAL NOTES:**  
 OUTER RACE - BEARING STEEL, HEAT TREATED  
 STUD - BEARING STEEL, ZONE HARDENED  
 NEEDLE ROLLER - BEARING STEEL, HEAT TREATED  
 WASHER - COLD ROLLED STEEL, HEAT TREATED  
 SEAL - SYNTHETIC

CUSTOMER PART#	.XX = ± .01 .XXX = ± .005 .XXXX = ± .0005 ANGLES = ± 1' INCH [METRIC] FRACTION = ± 1/32
CHANGE NOTE:	

CARTER MANUFACTURING IS NOT RESPONSIBLE FOR TYPOGRAPHICAL ERRORS	
REVISION	
<b>C</b>	<b>AUTHOR. BY</b>
DB	JAF
<b>REV. BY</b>	<b>DATE</b>
SGW	6/23/2011

<b>CARTER MANUFACTURING CO., INC.</b>					
GRAND HAVEN, MICHIGAN 49417					
PART NAME: ASSEMBLY			SHEET 1 OF 2		
<b>SALES</b>	<b>MATERIAL</b>	<b>CHK'D BY</b>	<b>DRAWN BY</b>	<b>AUTHOR. BY</b>	<b>REV. BY</b>
MD	NOTED	MD	JAF	DB	SGW
<b>DATE</b>	<b>DATE</b>	<b>DATE</b>	<b>DATE</b>	<b>DATE</b>	<b>DATE</b>
6/23/2011	6/23/2011	6/23/2011	6/13/2006	6/23/2011	6/23/2011
<b>CCNB-16-NSB</b>					