

NOTES:
1. BEARING IS PACKED WITH GREASE
2. ALL EXPOSED SURFACES ARE BLACK OXIDED

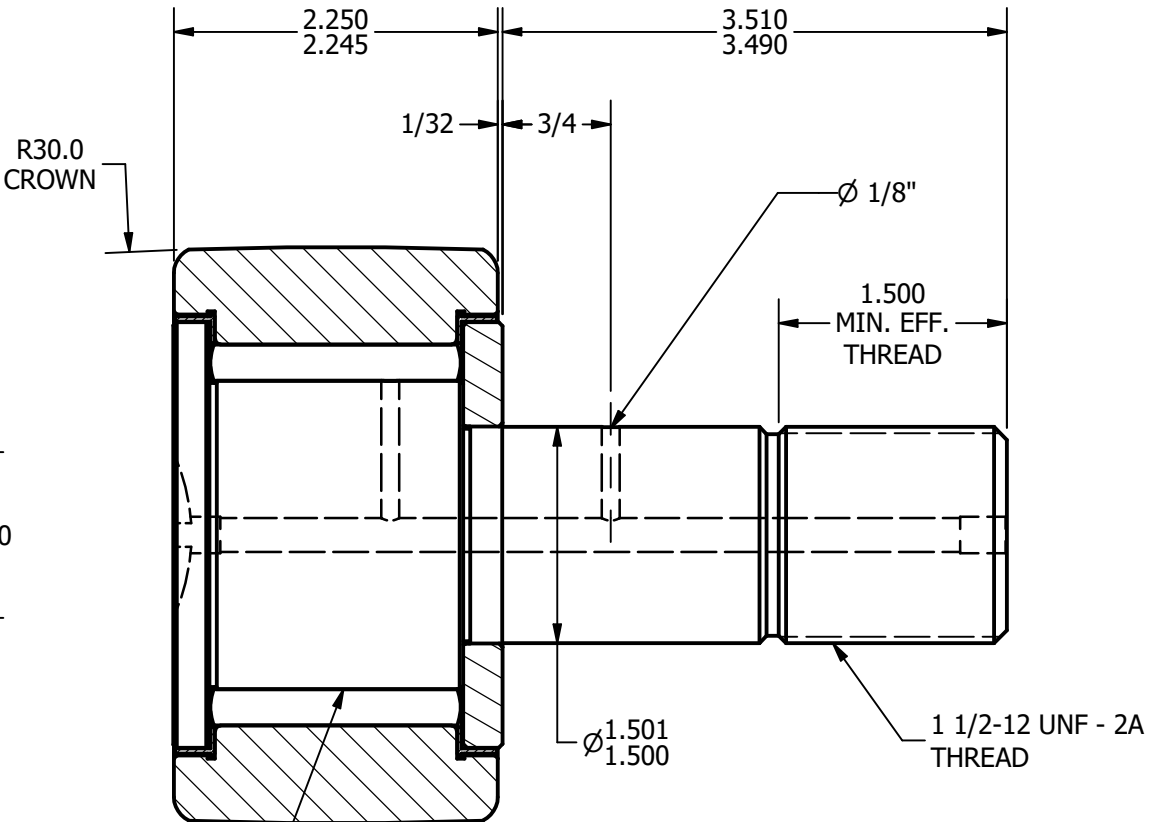
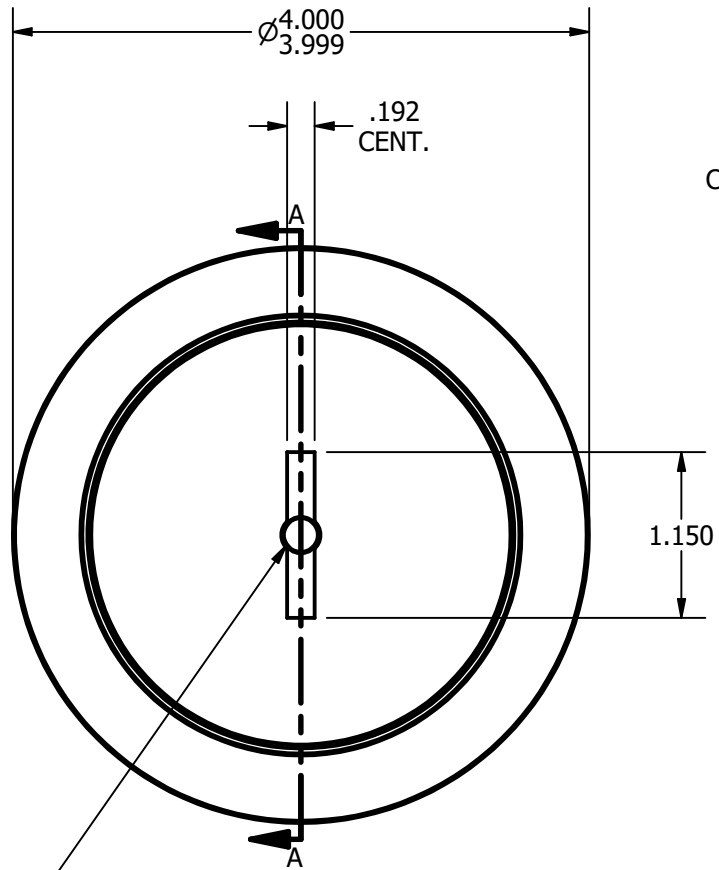
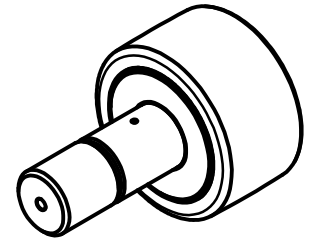

RADIAL BASIC DYNAMIC RATING (POUNDS) 29,985
MAXIMUM STATIC CAPACITY (POUNDS) 44,770

MATERIAL NOTES:
OUTER - BEARING STEEL, HEAT TREATED
STUD - BEARING STEEL, ZONE HARDENED
ROLLER - BEARING STEEL, HEAT TREATED
WASHER - COLD ROLLED STEEL, HEAT TREATED
SEAL - SYNTHETIC

<i>CUSTOMER PART#</i>	.XX = ± .01 .XXX = ± .005 .XXXX = ± .0005 ANGLES = ± 1° INCH [METRIC]
CHANGE NOTE:	

CARTER MANUFACTURING IS NOT RESPONSIBLE FOR TYPOGRAPHICAL ERRORS	
REVISION	
A	<i>AUTHOR. BY</i> JGV
<i>REV. BY</i>	<i>DATE</i>
EMD	7/6/2006

CARTER MANUFACTURING CO., INC.					
GRAND HAVEN, MICHIGAN 49417					
PART NAME: Assembly			SHEET 1 OF 2		
<i>SALES</i>	<i>MATERIAL</i>	<i>DATE</i>	<i>DATE</i>	<i>DATE</i>	<i>DRAWING NO.</i>
KPR	NOTED	7/4/2006	7/6/2006	7/6/2006	CCNB-128-S