

- NOTES:  
 1. BUSHING IS IMPREGNATED WITH OIL  
 2. ALL EXPOSED SURFACES HAVE BLACK OXIDE

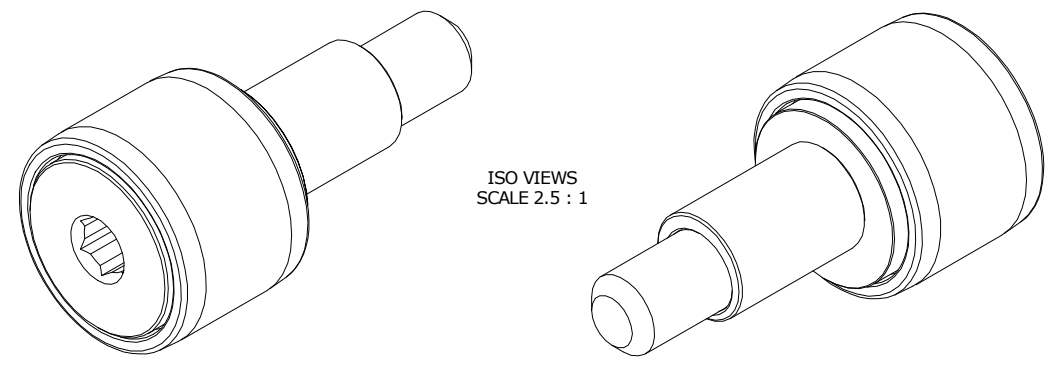

ISO VIEWS  
SCALE 2.5 : 1

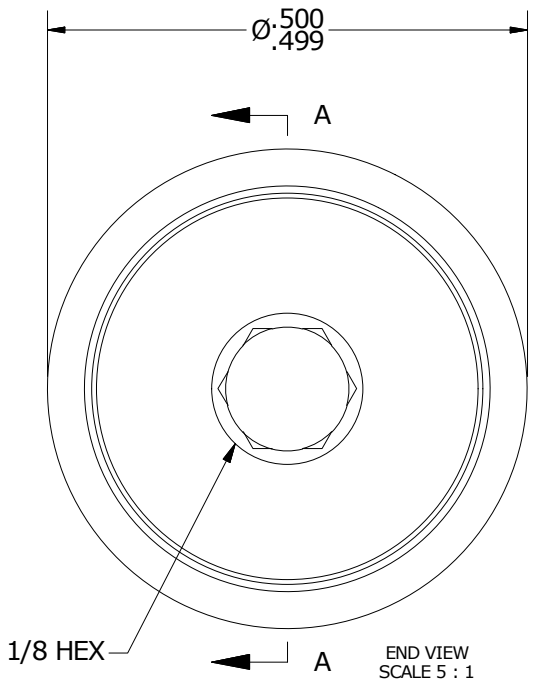

END VIEW  
SCALE 5 : 1

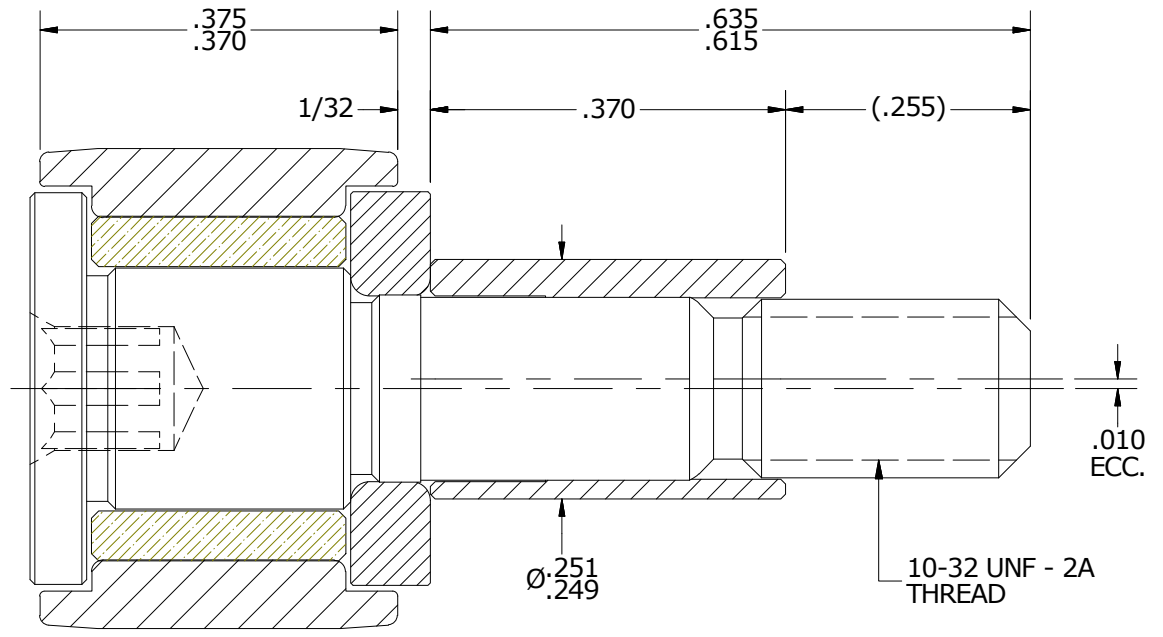

SECTION A-A  
SCALE 5 : 1

MATERIAL NOTES:

- OUTER RING - BEARING STEEL, HEAT TREATED
- STUD - COLD ROLLED STEEL
- WASHER - BEARING STEEL, HEAT TREATED
- BUSHING - SINTERED BRONZE
- ECCENTRIC SLEEVE - COLD ROLLED STEEL

CUSTOMER PART#	XX = ± .01 XXX = ± .005 XXXX = ± .0005 ANGLES = ± 1' INCH [METRIC] FRACTION = ± 1/32
ENGINEERING CHANGE ORDER NOTE	

CARTER MANUFACTURING IS NOT RESPONSIBLE FOR TYPOGRAPHICAL ERRORS

**CARTER MANUFACTURING CO., INC.**  
 GRAND HAVEN, MICHIGAN 49417

REVISION		PART NAME: ASSEMBLY					
<b>A</b>	AUTHOR BY HG	DRAWN BY SGW	CHK'D BY MD	SALES KR	MATERIAL NOTED		
REVISION BY SGW	DATE 8/1/2017	DATE 8/1/2017	DATE 8/1/2017	DATE 8/1/2017	SHEET 1 OF 2		