

LOAD RATINGS	
RATING	Lbs
RADIAL BASIC DYNAMIC	4,350
MAXIMUM STATIC CAPACITY	4,000

NOTES:
 1. BEARING IS PACKED WITH CARTER STANDARD H1 FOOD GRADE GREASE

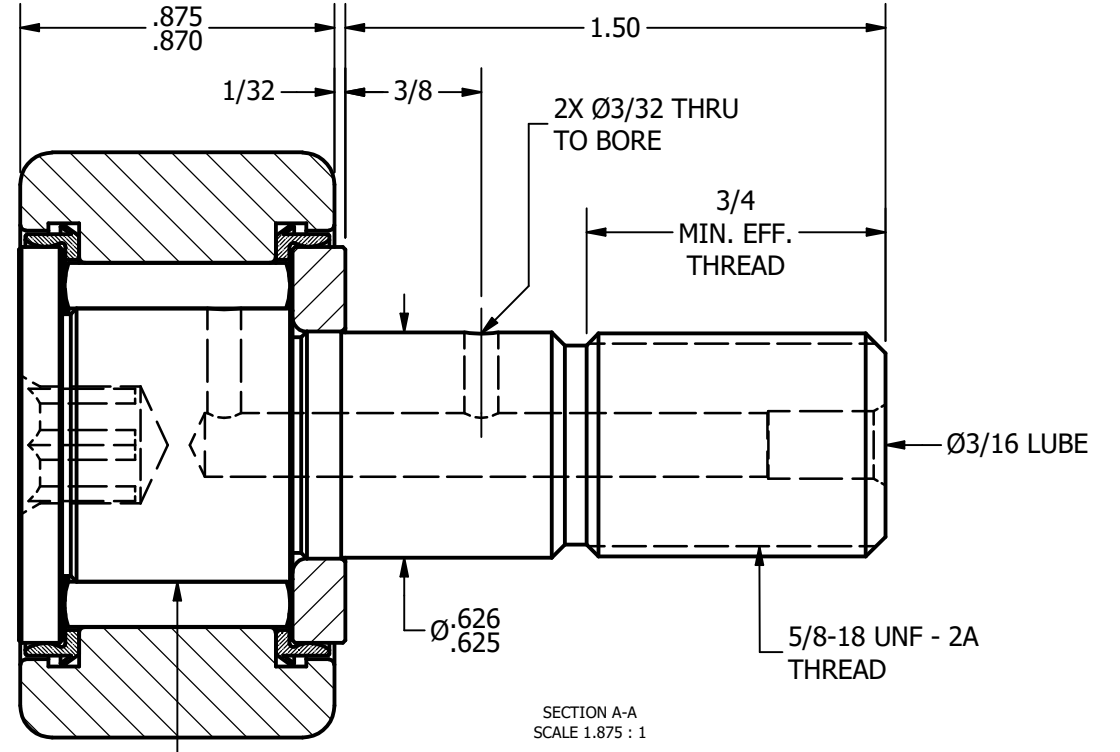
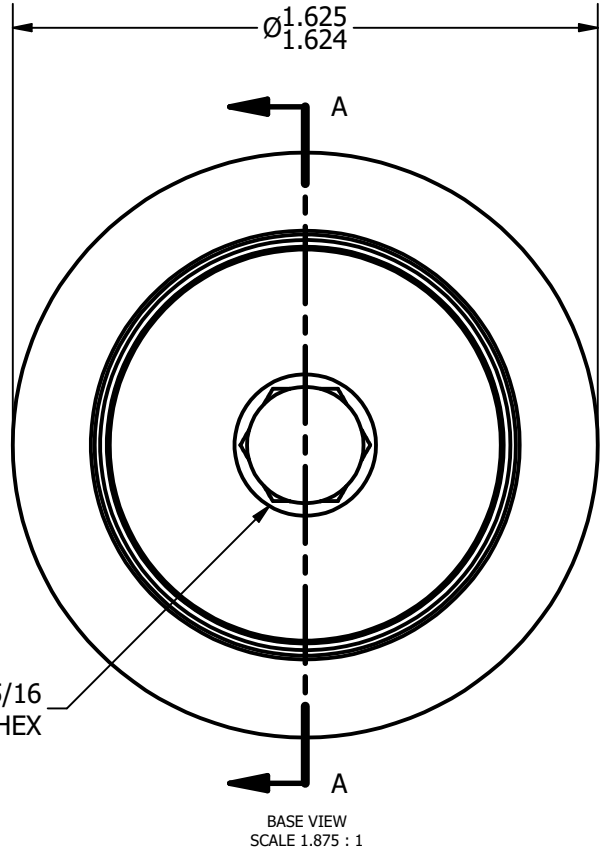
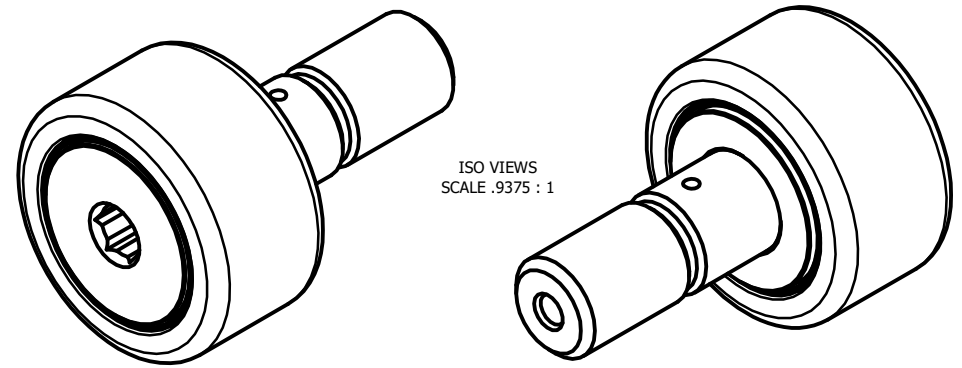

MATERIAL NOTES:
 OUTER RACE - 440C STAINLESS STEEL, HEAT TREATED
 STUD - 440C STAINLESS STEEL, ZONE HARDENED
 NEEDLE ROLLERS - 440C STAINLESS STEEL, HEAT TREATED
 WASHER - 440C STAINLESS STEEL, HEAT TREATED
 SEALS - SYNTHETIC

CUSTOMER PART#	.XX = ± .01 .XXX = ± .005 .XXXX = ± .0005 ANGLES = ± 1° INCH [METRIC] FRACTION = ± 1/32
CHANGE NOTE:	

CARTER MANUFACTURING IS NOT RESPONSIBLE FOR TYPOGRAPHICAL ERRORS	
REVISION	
B	AUTHOR. BY DB
REV. BY MD	DATE 3/26/2013

CARTER MANUFACTURING CO., INC.					
GRAND HAVEN, MICHIGAN 49417					
PART NAME: ASSEMBLY			SHEET 1 OF 2		
	AUTHOR. BY	DRAWN BY	CHK'D BY	SALES	MATERIAL
	DB	AJH	SGW	KPR	NOTED
	DATE	DATE	DATE	DATE	DRAWING NO.
	3/26/2013	8/9/2001	3/26/2013	8/8/2001	SC-52-SB