

LOAD RATINGS		
RATING	lbf	Newtons
RADIAL BASIC DYNAMIC	8,090	35,896
MAXIMUM STATIC CAPACITY	21,140	94,035

RECOMMENDED MOUNTING HOLE Ø		
Limit	Inch	mm
MIN	1.1250	28.5750
MAX	1.1255	28.5877

MAXIMUM CLAMPING TORQUE		
Thread Type	Inch Lbs	Nm
DRY	2,800	316
LUBRICATED	1,400	158

- NOTES:
- BEARING IS PACKED WITH NLGI GRADE 2, LITHIUM BASED GREASE (UNLESS OTHERWISE SPECIFIED)
 - ALL EXPOSED STEEL SURFACES HAVE BLACK OXIDE
 - LIMITING SPEED:
 - A. GREASE = 1,400 RPM

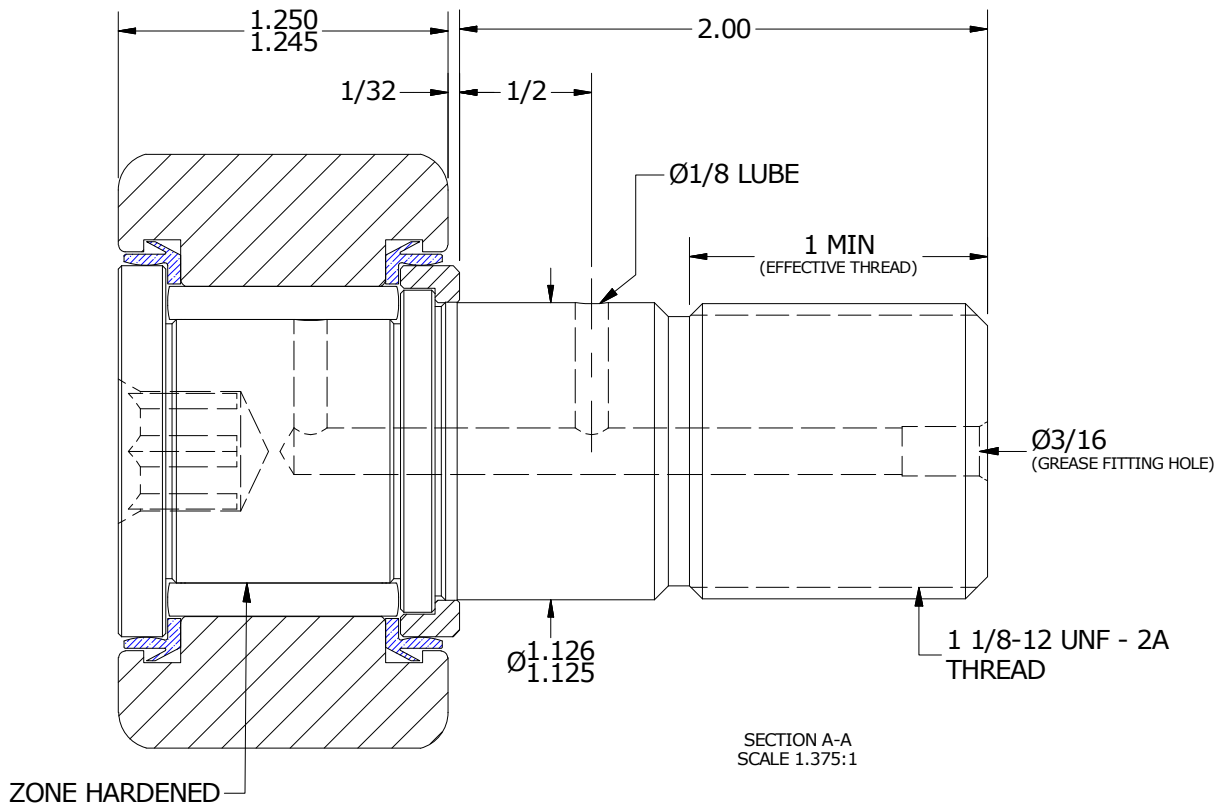
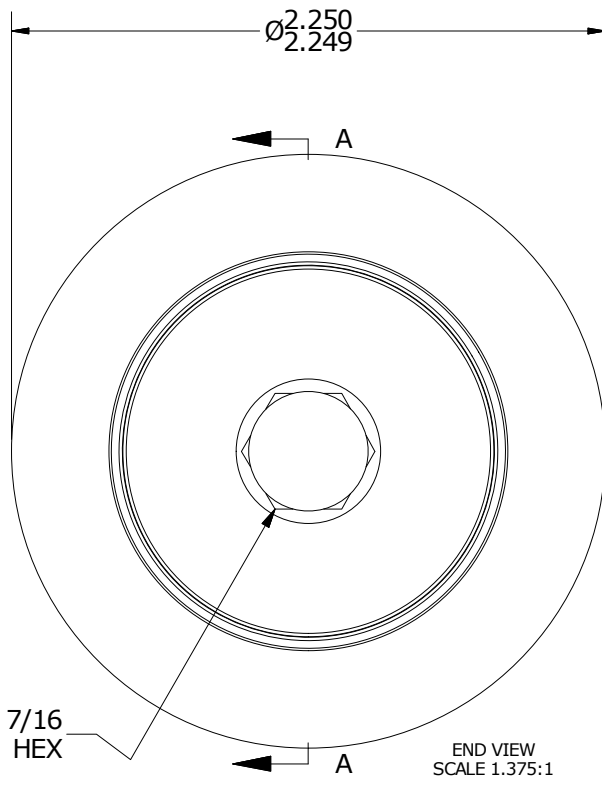
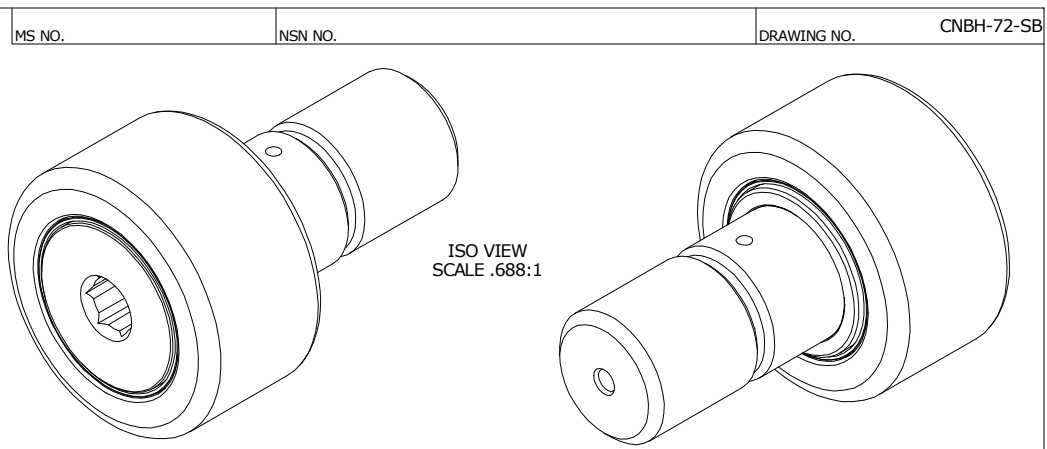

MATERIAL NOTES:

OUTER RING - BEARING STEEL, HEAT TREATED
 STUD - BEARING STEEL, ZONE HARDENED
 NEEDLE ROLLER(S) - BEARING STEEL, HEAT TREATED
 WASHER - BEARING STEEL, HEAT TREATED
 SEAL(S) - SYNTHETIC

CUSTOMER PART#	XX = ± .01 XXX = ± .005 XXXX = ± .0005 ANGLES = ± 1' INCH [METRIC] FRACTION = ± 1/32
ENGINEERING CHANGE ORDER NOTE	

CARTER MANUFACTURING IS NOT RESPONSIBLE FOR TYPOGRAPHICAL ERRORS		CARTER MANUFACTURING CO., INC. GRAND HAVEN, MICHIGAN 49417			
REVISION		PART NAME: ASSEMBLY		PRODUCT TYPE: CNB	
C	AUTHOR BY HG	DRAWN BY GJP	CHK'D BY MD	SALES KR	MATERIAL NOTED
REVISION BY SGW	DATE 7/19/2018	DATE 11/16/1999	DATE 7/19/2018	DATE 7/19/2018	SHEET 1 OF 2