

LOAD RATINGS		
RATING	lbf	Newtons
RADIAL BASIC DYNAMIC	4,840	21,529
MAXIMUM STATIC CAPACITY	11,280	50,176

- NOTES:
1. BEARING IS PACKED WITH NLGI GRADE 2, LITHIUM BASED (UNLESS OTHERWISE SPECIFIED)
 2. ALL EXPOSED SURFACES HAVE BLACK OXIDE
 3. LIMITING SPEED:
A. GREASE = 2,500 RPM

MS NO.	NSN NO.	DRAWING NO.	CNBH-48-SB
--------	---------	-------------	------------

RECOMMENDED MOUNTING HOLE Ø		
Limit	Inch	mm
MIN	.8750	22.2250
MAX	.8755	22.2377

MAXIMUM CLAMPING TORQUE		
Thread Type	Inch Lbs	Nm
DRY	1,500	169.5
LUBRICATED	750	84.7

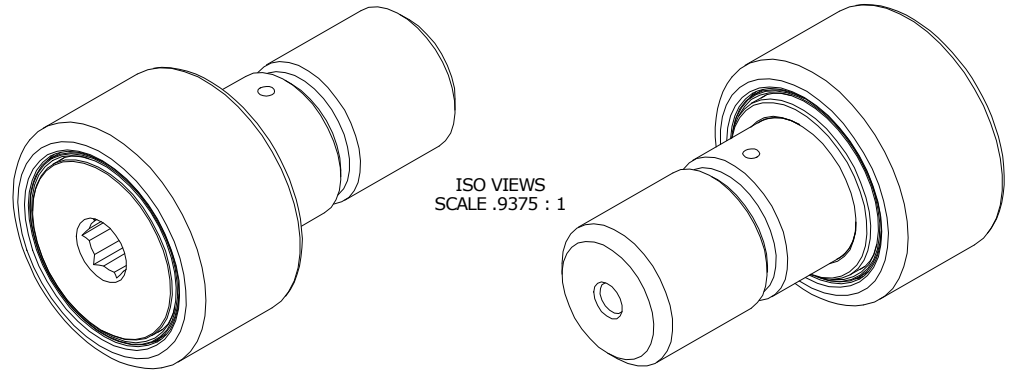

ISO VIEWS
SCALE .9375 : 1

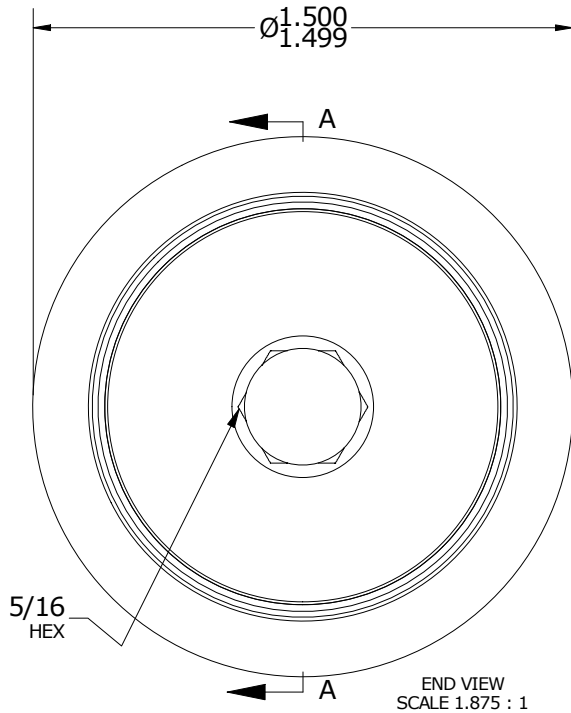

END VIEW
SCALE 1.875 : 1

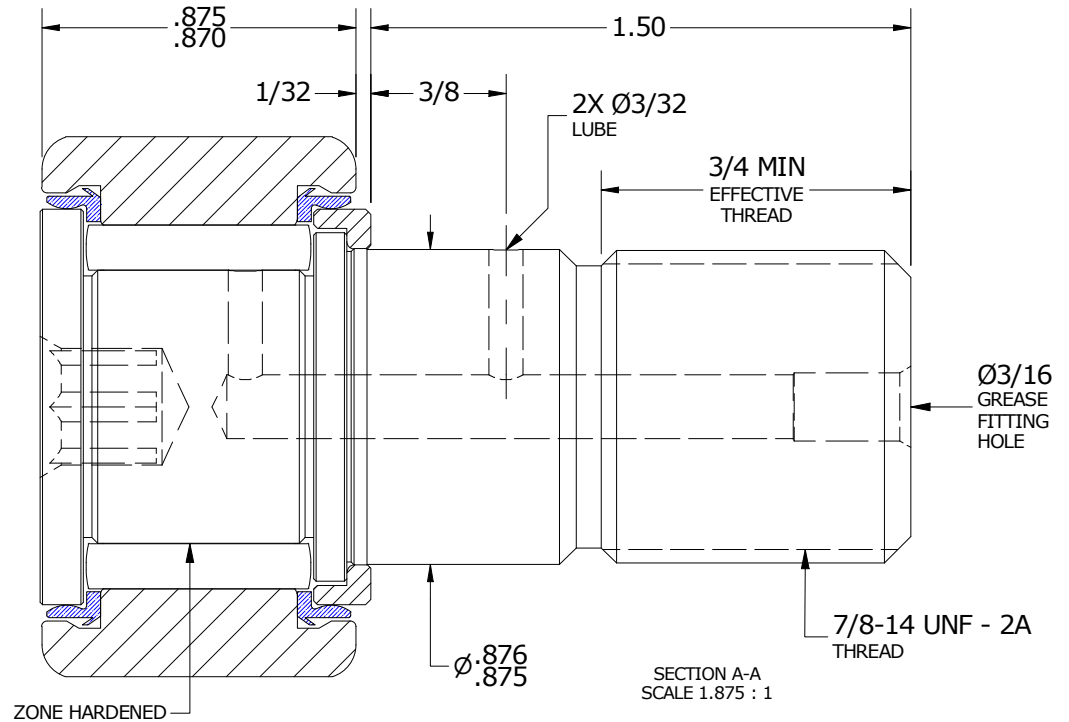

SECTION A-A
SCALE 1.875 : 1

MATERIAL NOTES:

- OUTER RING - BEARING STEEL, HEAT TREATED
- STUD - BEARING STEEL, ZONE HARDENED
- NEEDLE ROLLER(S) - BEARING STEEL, HEAT TREATED
- WASHER - BEARING STEEL, HEAT TREATED
- SEAL(S) - SYNTHETIC

CUSTOMER PART#

XX = ± .01
XXX = ± .005
XXXX = ± .0005
ANGLES = ± 1'
INCH [METRIC]
FRACTION = ± 1/32

CARTER MANUFACTURING IS NOT RESPONSIBLE FOR TYPOGRAPHICAL ERRORS

CARTER MANUFACTURING CO., INC.
GRAND HAVEN, MICHIGAN 49417

ENGINEERING CHANGE ORDER NOTE

REVISION

PART NAME: ASSEMBLY

PRODUCT TYPE: CNB

C

AUTHOR BY
DB

DRAWN BY
GJP

CHK'D BY
SGW

SALES
KR

MATERIAL
NOTED

REVISION BY
MD

DATE
3/26/2013

DATE
8/11/1999

DATE
3/26/2013

DATE
10/21/2010

SHEET
1 OF 2