

LOAD RATINGS		
RATING	lbf	Newtons
RADIAL BASIC DYNAMIC	8,090	35,896
MAXIMUM STATIC CAPACITY	21,140	94,035

MS NO. \_\_\_\_\_ NSN NO. \_\_\_\_\_ DRAWING NO. CCNBH-72-SB

RECOMMENDED MOUNTING HOLE Ø		
Limit	Inch	mm
MIN	1.1250	28.5750
MAX	1.1255	28.5877

- NOTES:
- BEARING IS PACKED WITH NLGI GRADE 2, LITHIUM BASED GREASE (UNLESS OTHERWISE SPECIFIED)
  - ALL EXPOSED STEEL SURFACES HAVE BLACK OXIDE
  - LIMITING SPEED:
    - A. GREASE = 1,400 RPM

MAXIMUM CLAMPING TORQUE		
Thread Type	Inch Lbs	Nm
DRY	2,800	316
LUBRICATED	1,400	158

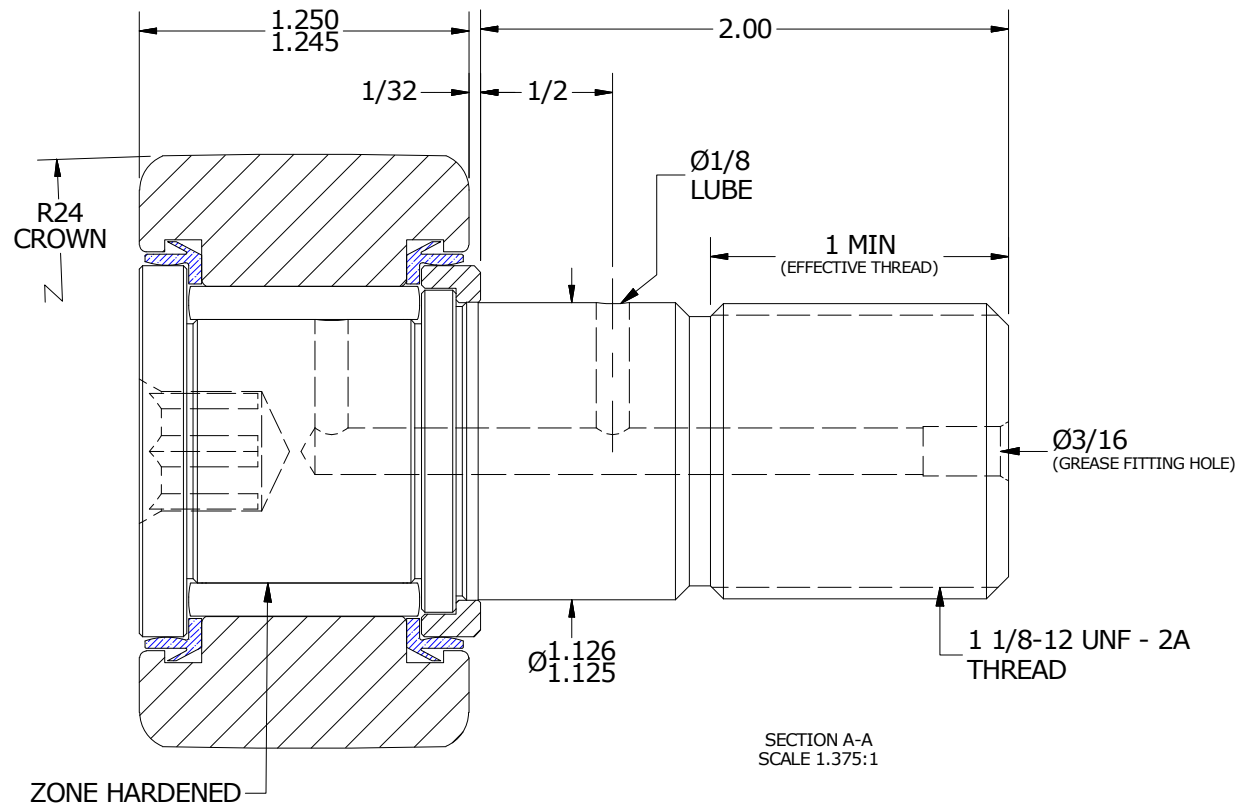
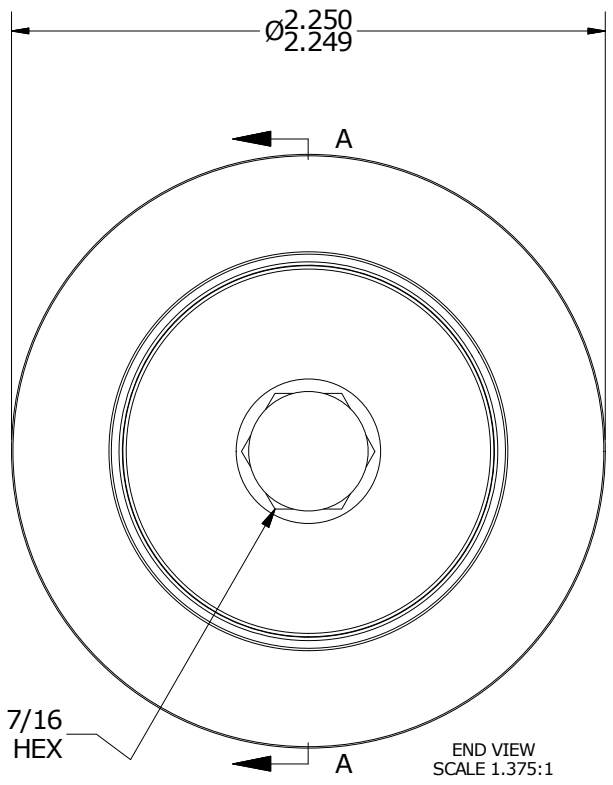
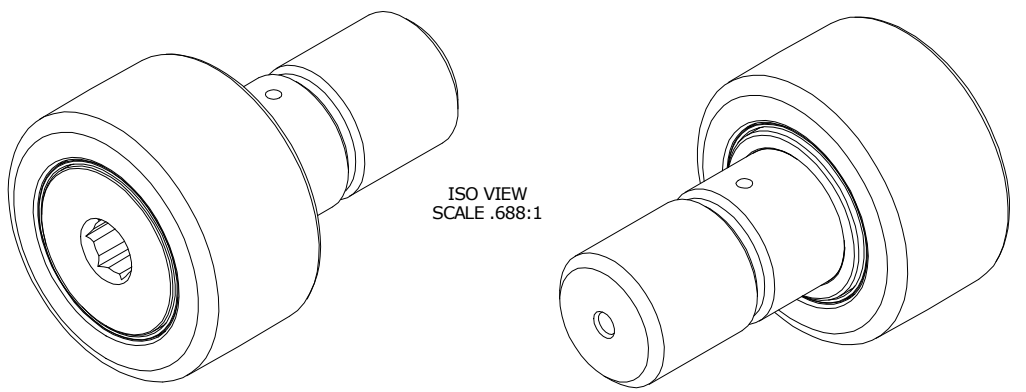

MATERIAL NOTES:

OUTER RING - BEARING STEEL, HEAT TREATED  
 STUD - BEARING STEEL, ZONE HARDENED  
 NEEDLE ROLLER(S) - BEARING STEEL, HEAT TREATED  
 WASHER - BEARING STEEL, HEAT TREATED  
 SEAL(S) - SYNTHETIC

CUSTOMER PART# \_\_\_\_\_  
 XX = ± .01  
 XXX = ± .005  
 XXXX = ± .0005  
 ANGLES = ± 1'  
 INCH [METRIC]  
 FRACTION = ± 1/32

CARTER MANUFACTURING IS NOT RESPONSIBLE FOR TYPOGRAPHICAL ERRORS

**CARTER MANUFACTURING CO., INC.**  
 GRAND HAVEN, MICHIGAN 49417

REVISION		PART NAME: ASSEMBLY		PRODUCT TYPE: CNB	
<b>B</b>	AUTHOR BY HG	DRAWN BY EMD	CHK'D BY MD	SALES KR	MATERIAL NOTED
REVISION BY JLB	DATE 8/2/2018	DATE 7/12/2006	DATE 8/2/2018	DATE 8/2/2018	SHEET 1 OF 2