

LOAD RATINGS		
RATING	lbf	Newtons
RADIAL BASIC DYNAMIC	3,930	17,481
MAXIMUM STATIC CAPACITY	8,500	37,810

MS NO. _____ NSN NO. _____ DRAWING NO. CCNBH-44

RECOMMENDED MOUNTING HOLE Ø		
Limit	Inch	mm
MIN	.7500	19.0500
MAX	.7505	19.0627

- NOTES:
1. BEARING IS PACKED WITH NLGI GRADE 2, LITHIUM BASED GREASE (UNLESS OTHERWISE SPECIFIED)
 2. ALL EXPOSED STEEL SURFACES HAVE BLACK OXIDE
 3. LIMITING SPEED:
 - A. GREASE = 3,100 RPM

MAXIMUM CLAMPING TORQUE		
Thread Type	Inch Lbs	Nm
DRY	1,250	141
LUBRICATED	625	70.5

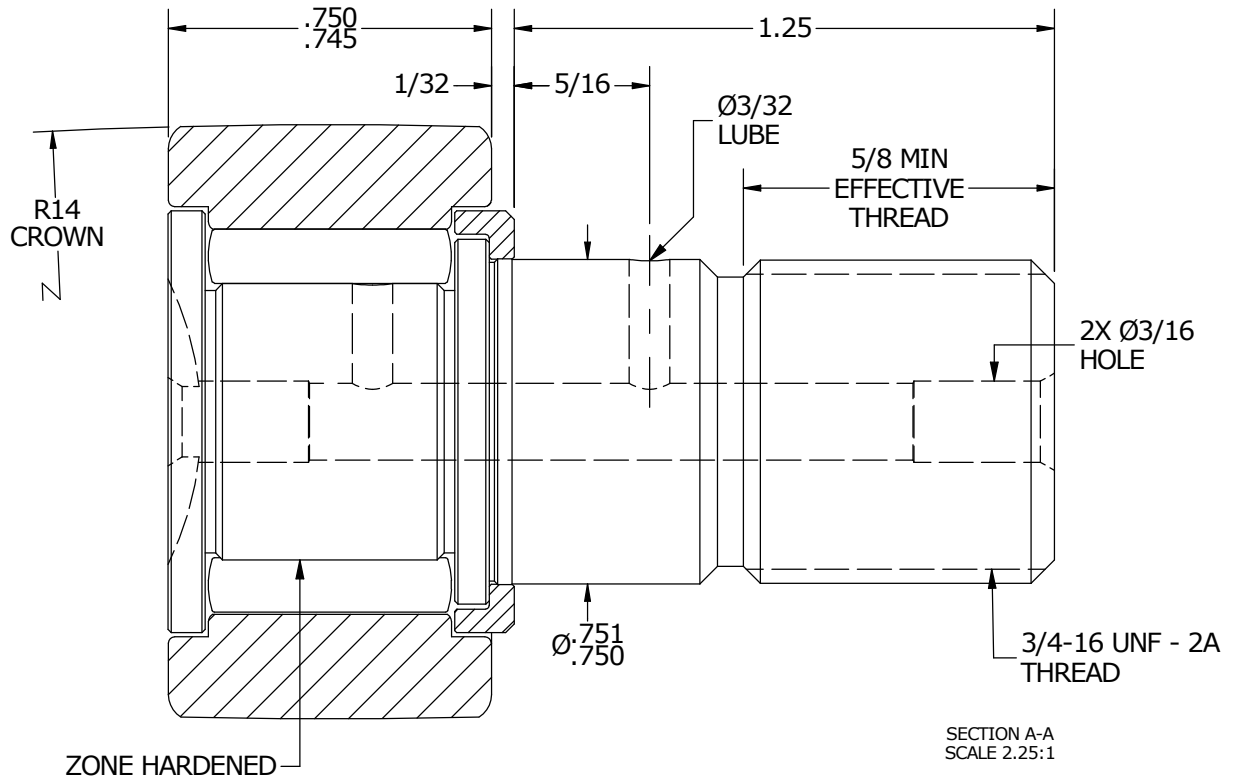
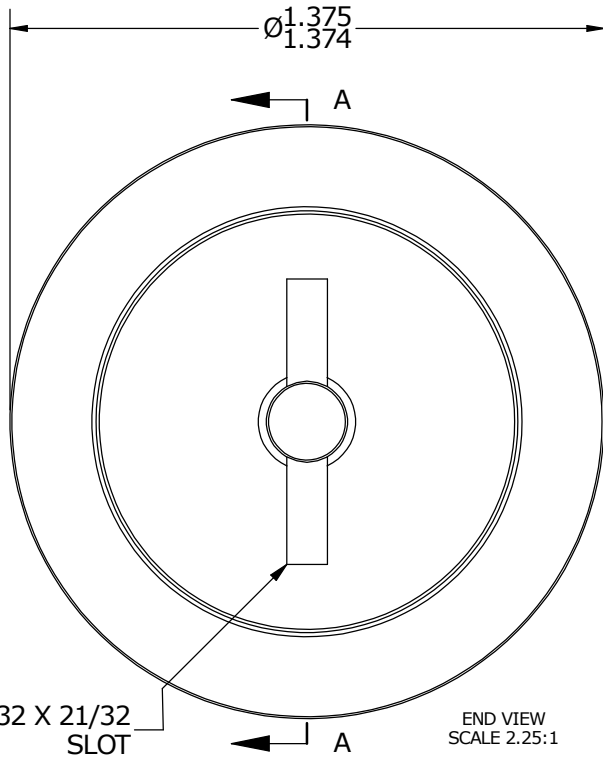
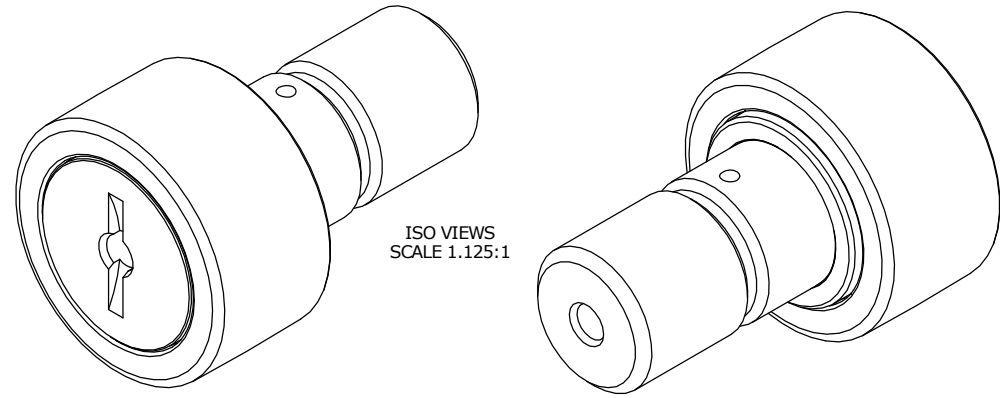

MATERIAL NOTES:

- OUTER RACE - BEARING STEEL, HEAT TREATED
- STUD - BEARING STEEL, ZONE HARDENED
- NEEDLE ROLLER - BEARING STEEL, HEAT TREATED
- WASHER - BEARING STEEL, HEAT TREATED*

CUSTOMER PART#

XX = ± .01
 XXX = ± .005
 XXXX = ± .0005
 ANGLES = ± 1'
 INCH [METRIC]
 FRACTION = ± 1/32

CARTER MANUFACTURING IS NOT RESPONSIBLE FOR TYPOGRAPHICAL ERRORS

CARTER MANUFACTURING CO., INC.
 GRAND HAVEN, MICHIGAN 49417

ENGINEERING CHANGE ORDER NOTE

REVISION

PART NAME: ASSEMBLY

REVISION	AUTHOR BY	DRAWN BY	CHK'D BY	SALES	MATERIAL
B	HG	JAF	MD	KR	NOTED
REVISION BY	DATE	DATE	DATE	DATE	SHEET
SGW	7/5/2016	7/3/2006	6/7/2016	7/15/2016	1 OF 2

*MAY BE CONSTRUCTED OF COLD ROLLED STEEL DEPENDING ON MATERIAL AVAILABILITY