

- NOTES:**
 1. BEARING IS PACKED WITH GREASE
 2. ALL EXPOSED SURFACES ARE BLACK OXIDED

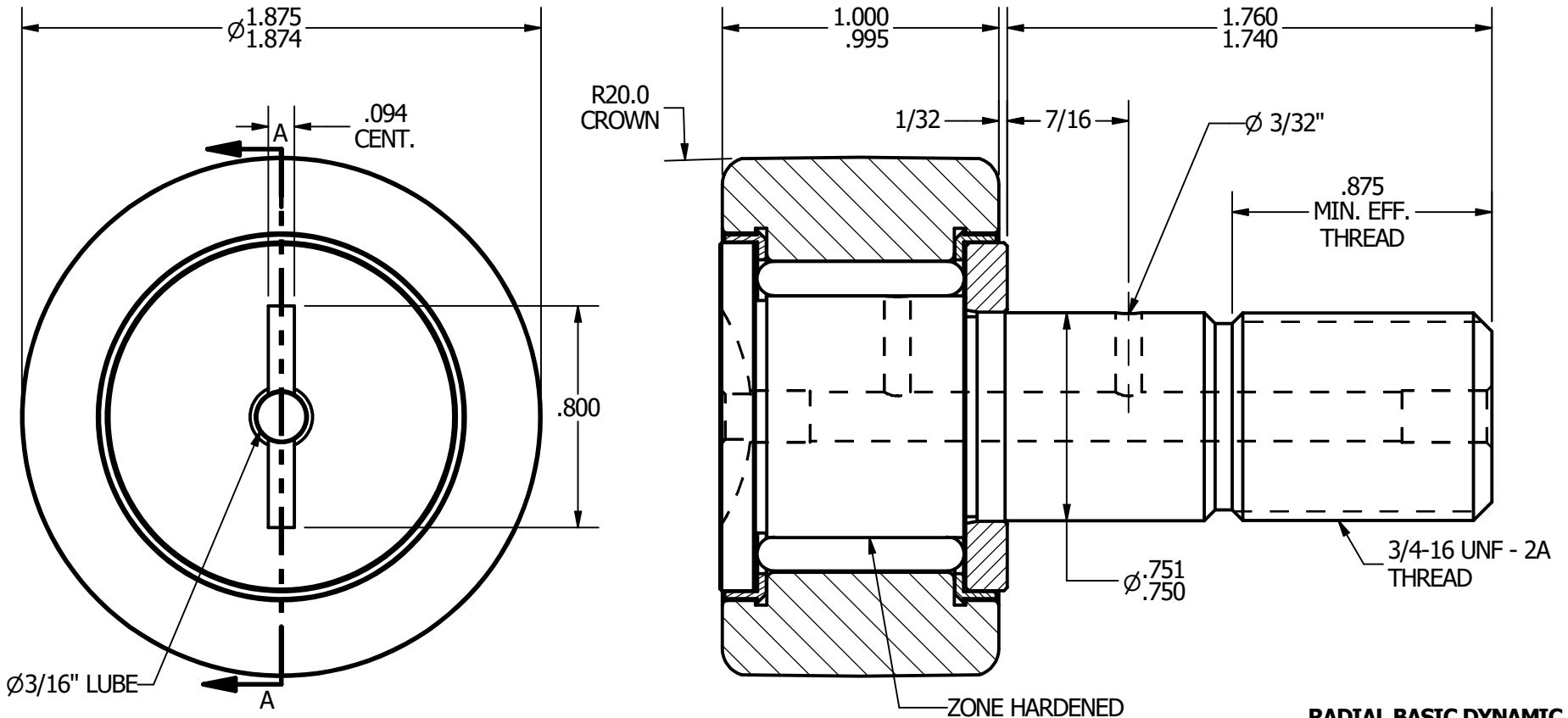
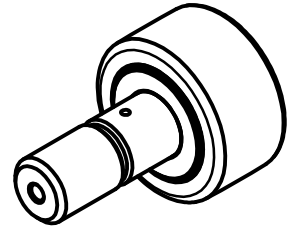

RADIAL BASIC DYNAMIC RATING (POUNDS) 6,385

MAXIMUM STATIC CAPACITY (POUNDS) 7,920

MATERIAL NOTES:

- OUTER - BEARING STEEL, HEAT TREATED**
- STUD - BEARING STEEL, ZONE HARDENED**
- ROLLER - BEARING STEEL, HEAT TREATED**
- WASHER - COLD ROLLED STEEL, HEAT TREATED**
- SEAL - SYNTHETIC**

CUSTOMER PART#

.XX = $\pm .01$
 .XXX = $\pm .005$
 .XXXX = $\pm .0005$
 ANGLES = $\pm 1'$
 INCH [METRIC]

CARTER MANUFACTURING IS NOT RESPONSIBLE FOR TYPOGRAPHICAL ERRORS

CARTER MANUFACTURING CO., INC.

GRAND HAVEN, MICHIGAN 49417

REVISION

PART NAME: ASSEMBLY

SHEET 1 OF 2

CHANGE NOTE:

A

REV. BY

AUTHOR. BY

DRAWN BY

CHK'D BY

SALES

MATERIAL

JGV

EMD

JGV

KPR

NOTED

DATE

DATE

DATE

DATE

DRAWING NO.

7/13/2006

7/13/2006

7/13/2006

7/12/2006

CCNB-60-S